

- Wall mounted
- Ceiling cassette
- Ceiling convertible
- Ducted

Chilled Water Fan Coil Unit Product Catalogue



CONTENTS

Wall Mounted



03

Ceiling Cassette



06



09



*with brushless DC motor

14

Ceiling Convertible



18



22

Ceiling Concealed



25







29

Ducted Blower



32

PRODUCTS OVERVIEW

| Cooling Capacity | | kW | | | | | | | | |
|---------------------------------------|---|----|----------------------|-----------------------|----|----|-------------|----|----|----|
| | | 0 | 5 | 10 | 15 | 20 | 25 | 30 | 35 | 40 |
| FWW-L |  | | 2/3/4/5/6 | | | | | | | |
| FWF-C |  | | 2/4/5 | | | | | | | |
| FWK-E/ FWKE-E/ FWKE-EH |  | | | 5/6/8/9/11/13 | | | | | | |
| FWE-E |  | | | 5/6/7/8/10/12 | | | | | | |
| FWE-D |  | | | 7/9/13 | | | | | | |
| FWC-C |  | | | 3/4/6/7/9/11/12/14/16 | | | | | | |
| FWC-FD |  | | 2/2.5/3.5 4/5/7/8 | | | | | | | |
| FUD-B |  | | | | | | 20/25/30/40 | | | |



Wall Mounted (50Hz)



FWW-L



Wireless controller
BRC52A



Wired controller
BRC51A (optional)

- Comfortable air flow and lower sound level
- Uniform air distribution
- Stylish flat-panel, easy maintenance
- Quiet mode, turbo mode
- Sleep function in cool and heat modes
- Auto restart with last-state-memory
- Valve or valveless control options
- Self-diagnosis features
- Compact and easy-to-use wireless controller
- NIM-abled



Wall Mounted (50Hz)

Comfortable air flow and lower sound level

User given more choice on preferable fan speed, quiet mode or automatic setting. With the introduction of SCR indoor fan motor, a step-less change of fan speed results in smooth airflow and unnoticeable sound level change during fan speed change.

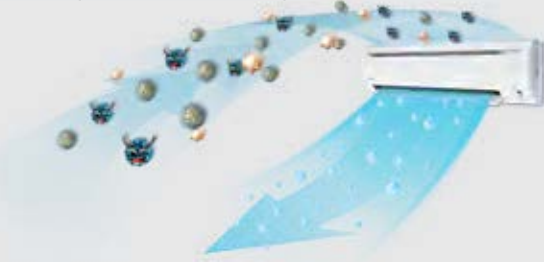

Stylish Flat-Panel

Ideal blend of style and functionality.

- The front panel is designed for contemporary style without compromising on function.
- Air intake area is designed to ensure smooth air flow profile for better sound quality and optimized volume.

Indoor Quiet Mode

More quiet room environment.

- With up to five selectable fan speeds, users are given more choices. By selecting Quiet mode, the sound pressure level is reduced down to an unobtrusive 24 dBA.
- To quickly cool down the room, Turbo mode can be selected for maximum cooling power and highest airflow.

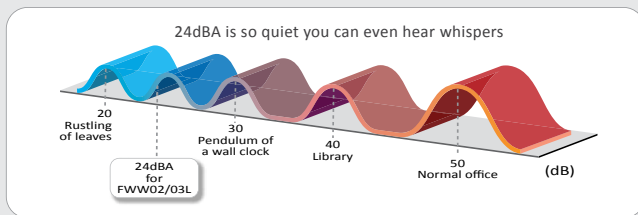

| | | | | | |
|-----------|-----|------|---|---|-------|
| | SL | L | M | H | Turbo |
| | | | | | |
| Fan Speed | Low | High | | | |

Turbo Mode

Turbo function is available in Cool and Heat modes only. Once it is activated, the air-conditioner will run on full power with indoor fan running at maximum speed for 20 minutes. This enables the set temperature to be achieved faster. If Turbo and Sleep are activated at the same time, the Sleep mode timer will be reset, it will resume after Turbo function is cleared.

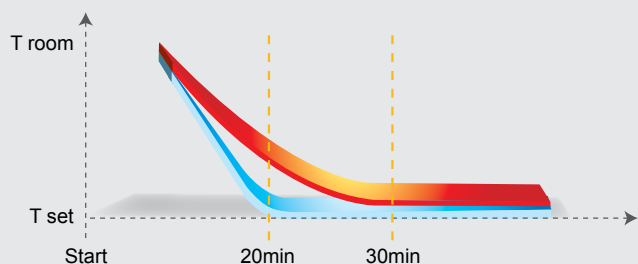

Self Diagnosis Features

This feature helps to detect any faults or malfunctioning in the system and provide user a warning by blinking of the LED lights.

Easy Maintenance

Air intake grill is easily detachable to be cleaned with water.

Sleep Mode

Pressing the Sleep button activates the Sleep Mode. This function prevents excessive cooling/heating for a pleasant sleep.

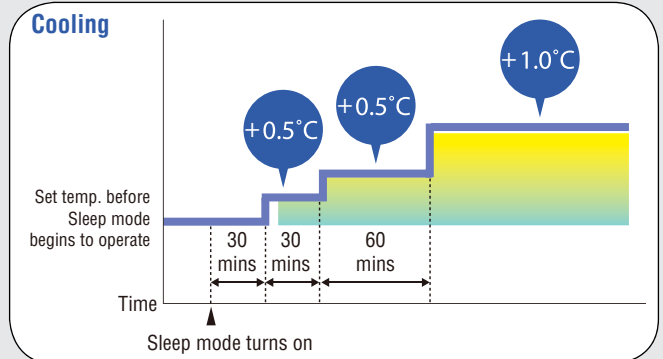

Cooling operation:

- 1) After 30 minutes, room temperature is raised by 0.5°C.
- 2) After 60 minutes, room temperature is raised by 0.5°C.
- 3) After 120 minutes, room temperature is raised by 1°C.

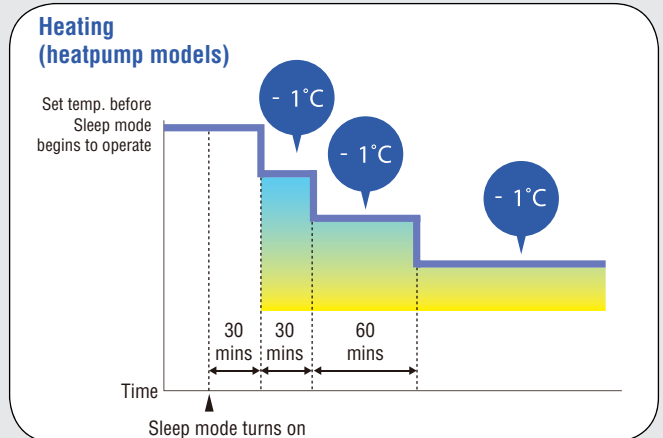

Heating operation:

- 1) After 30 minutes, room temperature is reduced by 1°C.
- 2) After 60 minutes, room temperature is reduced by 1°C.
- 3) After 120 minutes, room temperature is reduced by 1°C.

Auto Restart with Last-State-Memory

In the event of a sudden power failure during operation, unit restarts automatically in 64 different recovery timing patterns (within 180 seconds to 244 seconds) and the unit will operate based on the previous setting (operating mode, temperature setting and fan speed).

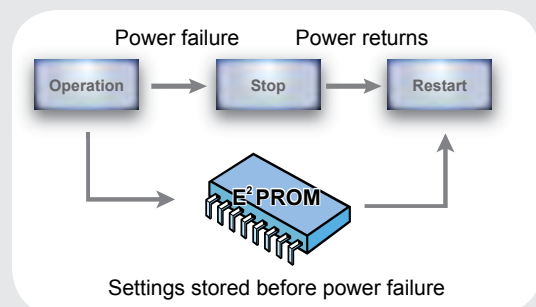

Uniform Air Distribution

Automated air swing ensures conditioned air distributed evenly.

Compact and Easy-to-use Wireless Controller

Wireless controller BRC52A comes as standard.

Wall Mounted (50Hz)

Specification for wall mounted

| Indoor model name | | | FWW02L | FWW03L | FWW04L | FWW05L | FWW06L |
|--|--------------------------|-----------------------------|--|-----------------------|-----------------------|-----------------------|-----------------------|
| Nominal cooling capacity | Btu/hr | | 8300 | 9200 | 11300 | 15500 | 18000 |
| | W | | 2430 | 2700 | 3310 | 4540 | 5280 |
| Nominal sensible cooling capacity | Btu/hr | | 6300 | 6900 | 9000 | 11700 | 14000 |
| | W | | 1850 | 2020 | 2640 | 3430 | 4100 |
| Nominal heating capacity (entering water temperature: 50°C) | Btu/hr | | 11000 | 12000 | 15000 | 20500 | 25000 |
| | W | | 3220 | 3520 | 4400 | 6010 | 7330 |
| Nominal total input power | W | | 31 | 32 | 42 | 53 | 72 |
| Nominal running current | A | | 0.19 | 0.20 | 0.21 | 0.29 | 0.34 |
| Power source | V/Ph/Hz | | 220-240 / 1 / 50 | | | | |
| Control | Air discharge | | Automatic louver (up & down) | | | | |
| | Operation | | LCD wireless micro-computer remote control | | | | |
| Airflow (H/M/L/Q) | cfm | | 260 / 230 / 200 / 180 | 280 / 250 / 220 / 190 | 370 / 320 / 260 / 240 | 510 / 450 / 390 / 360 | 620 / 520 / 460 / 440 |
| Nominal water flow rate | USGPM | | 1.85 | 2.03 | 2.51 | 3.43 | 4.01 |
| | liters/min | | 7.00 | 7.68 | 9.50 | 13.00 | 15.18 |
| Head loss (Cooling) | kPa | | 34 | 24 | 31 | 30 | 36 |
| Head loss (Heating): 50°C | kPa | | 29 | 20 | 25 | 27 | 33 |
| Max. working pressure | kPa | | 1608 | | | | |
| Surface air velocity | m/s | | 0.68 | 0.74 | 0.97 | 0.83 | 1.01 |
| Sound pressure level (H/M/L/Q) | dBA | | 34 / 29 / 25 / 24 | 35 / 30 / 25 / 24 | 42 / 39 / 32 / 29 | 42 / 38 / 34 / 32 | 46 / 42 / 39 / 37 |
| Unit dimension (HxWxD) | mm | | 288 x 800 x 206 | | | 310 x 1065 x 224 | |
| Packing dimension (HxWxD) | mm | | 344 x 874 x 274 | | | 386 x 1136 x 314 | |
| Unit weight | kg | | 9 | | | 14 | |
| Condensate drain size | mm | | 19.05 | | | | |
| Pipe connection | mm | | 12.70 BSP female thread adaptor | | | | |
| Fan | Type | | Cross flow fan | | | | |
| | Drive | | Direct | | | | |
| | Fan speed (H/M/L) | rpm | 1030 / 890 / 760 | 1050 / 910 / 780 | 1310 / 1150 / 955 | 1035 / 920 / 825 | 1250 / 1070 / 970 |
| Fan motor | Type | | Single phase SCR | | | | |
| | Index of Protection (IP) | | IP20 | | | IP44 | |
| | Insulation grade | | E | | | | |
| | Rated input power | W | 31 / 29 / 25 | 32 / 31 / 29 | 42 / 37 / 33 | 53 / 47 / 42 | 72 / 68 / 60 |
| | Rated running current | A | 0.19 / 0.18 / 0.17 | 0.20 / 0.20 / 0.19 | 0.21 / 0.20 / 0.19 | 0.29 / 0.26 / 0.25 | 0.34 / 0.32 / 0.31 |
| | Starting current | A | 0.40 | 0.40 | 0.40 | 0.30 | 0.43 |
| | Motor output | W | 18 | 18 | 18 | 26 | 30 |
| Poles | | | 4 | | | | |
| Coil | Tube | Material | Copper | | | | |
| | | Diameter (mm) | 7.00 | | | | |
| | Fin | Material | Aluminium | | | | |
| | | Face area (m ²) | 0.18 | | | 0.29 | |
| | Row | | | 2 | | | |
| Water volume | liter | 0.52 | 0.58 | 0.58 | 0.95 | 0.95 | |
| Air quality | Filter type | | Washable saranet filter | | | | |
| | Filter quantity | pc | 2 | | | | |
| Casing | Colour | | White | | | | |

| Mode | Cooling | Heating |
|----------------------------|-------------------|----------------------|
| Entering air temperature | 27°C DB / 19°C WB | 20°C DB |
| Entering water temperature | 7°C | 50°C (2-pipe system) |
| Leaving water temperature | 12°C | |

All specifications are subjected to change by the manufacturer without prior notice.

Ceiling Cassette Compact 2x2 (50Hz)



FWF-C



Wireless controller
BRC52A



Wired controller
BRC51A

- Compact design
- Fresh air intake
- Stylish and slim panel
- Built-in high head drain pump and water flow switch
- 4-way air discharge and air swing
- Sleep function in cool and heat modes
- Branch duct connection
- Auto restart with last-state-memory
- Valve or valveless control options
- Self-diagnosis features
- Choices of wired or wireless controller
- NIM-abled



Ceiling Cassette Compact 2x2 (50Hz)

Compact Design

Ceiling Cassette C Series body dimension is only 570 mm x 570 mm which can easily fit into a 600 mm ceiling grid.

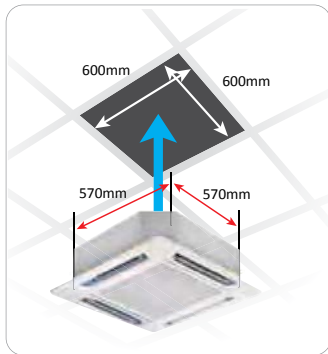

Fresh Air Intake

- Knock out hole is available at the unit.
- Installation and accessories such as booster fan is field supplied and installed.
- Fresh air intake is within 20% of the total air flow.

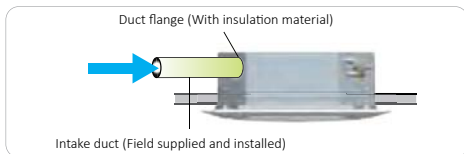

Stylish & Slim Panel

The slim panel can be blended easily into decoration and interior design.

Built In High Head Drain Pump & Water Flow Switch
The unit comes with a 700 mm built-in high head drain pump. A safety float is incorporated in the drain pump to monitor its water level.

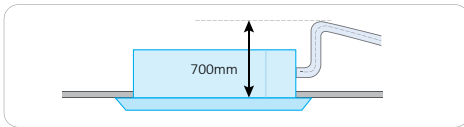

4-Way Air Discharge and Air Swing

It comes with 4-way air discharge and air swing function to ensure better air distribution and circulation in the room.



Self Diagnosis Features

This feature helps to detect any faults or malfunctioning in the system and provide user a warning by blinking of the LED lights.

Branch Duct Connection

Improves air flow distribution when there is an obstruction. It allows for air conditioning of two rooms simultaneously.

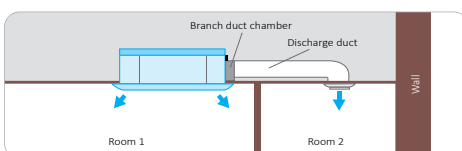

Sleep Mode

Pressing the Sleep button activates the Sleep Mode. This function prevents excessive cooling/heating for a pleasant sleep.

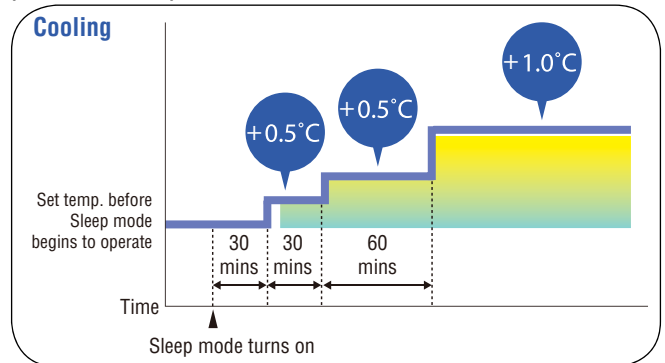

Cooling operation:

- 1) After 30 minutes, room temperature is raised by 0.5°C.
- 2) After 60 minutes, room temperature is raised by 0.5°C.
- 3) After 120 minutes, room temperature is raised by 1°C.

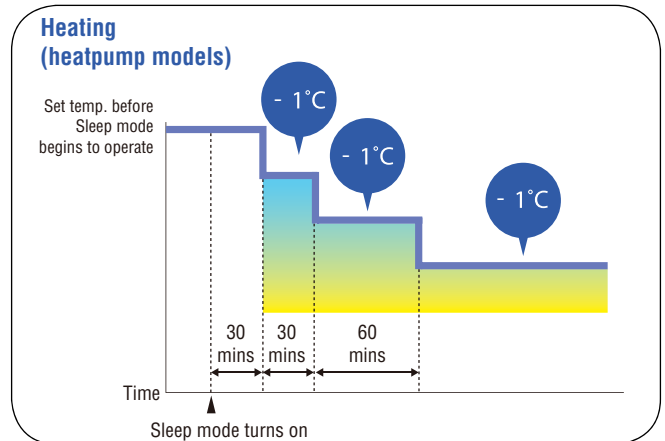

Heating operation:

- 1) After 30 minutes, room temperature is reduced by 1°C.
- 2) After 60 minutes, room temperature is reduced by 1°C.
- 3) After 120 minutes, room temperature is reduced by 1°C.

Auto Restart with Last-State-Memory

In the event of a sudden power failure during operation, unit restarts automatically in 64 different recovery timing patterns (within 180 seconds to 244 seconds) and the unit will operate based on the previous setting (operating mode, temperature setting and fan speed).

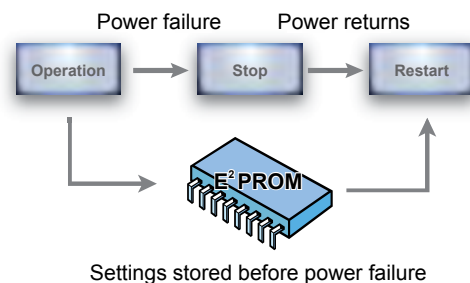

Valve or Valveless Control Options

The design is flexible enough to allow for either valve or valveless control installation.

Choices of Wired or Wireless Controller

Choices of wired BRC51A or wireless BRC52A.

Ceiling Cassette Compact 2x2 (50Hz)

Specification for ceiling cassette compact

| Indoor model name | | | FWF02C | FWF04C | FWF05C |
|--|-------------------------------|-----------------------------|--|--------------------|--------------------|
| Nominal cooling capacity | Btu/hr | | 8500 | 14000 | 15500 |
| | W | | 2490 | 4100 | 4540 |
| Nominal sensible cooling capacity | Btu/hr | | 6500 | 10000 | 11500 |
| | W | | 1910 | 2930 | 3370 |
| Nominal heating capacity (entering water temperature: 50°C) | Btu/hr | | 12000 | 16000 | 18000 |
| | W | | 3520 | 4690 | 5280 |
| Nominal total input power | W | | 63 | 64 | 79 |
| Nominal running current | A | | 0.28 | 0.28 | 0.35 |
| Power source | V/Ph/Hz | | 220-240 / 1 / 50 | | |
| Control | Air discharge | | 4-way automatic louver (up & down) | | |
| | Operation | | LCD wireless micro-computer remote control | | |
| Airflow (H/M/L) | cfm | | 380 / 290 / 230 | 400 / 310 / 220 | 440 / 330 / 280 |
| Nominal water flow rate | USGPM | | 2.03 | 3.43 | 3.57 |
| | liters/min | | 7.68 | 12.98 | 13.51 |
| Head loss (Cooling) | kPa | | 19.3 | 26.9 | 28.8 |
| Head loss (Heating): 50°C | kPa | | 16.8 | 23.9 | 26.5 |
| Max. working pressure | kPa | | 1608 | | |
| Surface air velocity | m/s | | 0.74 | 0.74 | 0.82 |
| Sound pressure level (H/M/L) | dB(A) | | 42 / 35 / 29 | 45 / 38 / 30 | 48 / 40 / 36 |
| Unit dimension (Unit dimension with panel) (HxWxD) | mm | | 250 X 570 X 570 (295 X 640 X 640) | | |
| Packing dimension (Panel dimension) (HxWxD) | mm | | 316 X 630 X 630 (126 X 700 X 726) | | |
| Unit weight + panel weight | kg | | 15 + 3 | 17 + 3 | |
| Condensate drain size | mm | | 19.05 | | |
| Pipe connection | mm | | 19.05 BSP female thread adaptor | | |
| Fan | Type | | Turbo fan | | |
| | Drive | | Direct | | |
| Fan speed (H/M/L) | rpm | | 725 / 565 / 460 | 810 / 630 / 480 | 900 / 700 / 610 |
| Fan motor | Type | | Permanent split capacitor (Induction) | | |
| | Index of Protection (IP) | | IP20 | | |
| | Insulation grade | | B | | |
| | Rated input power (H/M/L) | W | 63 / 51 / 46 | 64 / 58 / 52 | 79 / 73 / 69 |
| | Rated running current (H/M/L) | A | 0.28 / 0.23 / 0.21 | 0.28 / 0.25 / 0.24 | 0.35 / 0.32 / 0.31 |
| | Starting current | A | 0.32 | 0.3 | 0.47 |
| | Motor output | W | 17 | 23 | 28 |
| Poles | | | 6 | | |
| Coil | Tube | Material | Copper | | |
| | | Diameter (mm) | 7.00 | | |
| | Fin | Material | Aluminium | | |
| | | Face area (m ²) | 0.24 | 0.25 | |
| | | Row | 1 | 2 | |
| Water volume | liter | 0.43 | 0.83 | | |
| Air quality | Filter type | | Washable saranet filter | | |
| | Filter quantity | pc | 1 | | |
| Casing | Colour | | White | | |

| Mode | Cooling | Heating |
|----------------------------|-------------------|----------------------|
| Entering air temperature | 27°C DB / 19°C WB | 20°C DB |
| Entering water temperature | 7°C | 50°C (2-pipe system) |
| Leaving water temperature | 12°C | |

All specifications are subjected to change by the manufacturer without prior notice.

Ceiling Cassette 3x3 (50Hz)



FWK-E

- Multi comfort - 3 air swing pattern control
- Fresh air intake
- Optimum air discharge
- Superior sound level
- Branch duct connection
- Low height design
- Built-in high head drain pump and water flow switch
- Modern and elegant panel
- Low water pressure drop
- Sleep function in cool and heat modes
- Auto restart with last-state-memory
- Valve or valveless control options
- Self-diagnosis features
- Choices of wired or wireless controller
- NIM-abled
- 4-pipe system availability*



Wireless controller
BRC52A



Wired controller
BRC51A



Ceiling Cassette 3x3 (50Hz)

Multi Comfort - 3 Air Swing Pattern Control

To increase the comfort level of the air conditioned area of FWK-E series, the system had been built in with three different types of air flow pattern to suit different requirements.

* The default setting is pattern 1. The air swing pattern can be selected via wireless controller.

Standard Setting

Louver is set to swing at the maximum angle for gentle drafts.

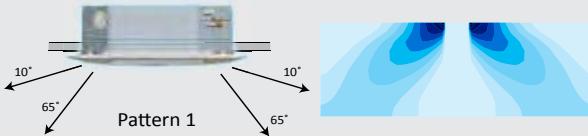

Draft Prevention Setting

With the aid of Coanda effect, direct draft which may lead to discomfort can be avoided.

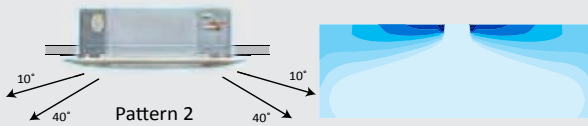

Soil Prevention Setting

Even distribution of cooling whilst ensuring ceiling to be kept spotless.

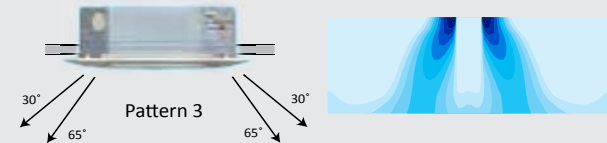

Fresh Air Intake

- Knock out hole is available at the unit.
- Installation and accessories such as booster fan is field supplied and installed.
- Fresh air intake is within 20% of the total air flow.

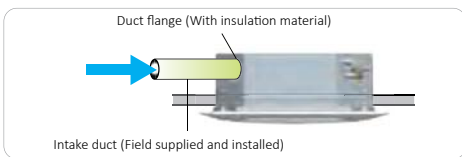

Optimum Air Discharge and Air Swing

Combining 4-way air discharge and large discharge area on each side, the ceiling cassette promotes uniform air distribution. The additional feature of automatic air swing helps to distribute the conditioned air evenly to every corners of the room.



Superior Sound Level

The ceiling cassette series is able to achieve exceptional low noise by adaption of Daikin's turbo fan technology. With 4 selectable fan speeds, users are given more choices. In Quiet mode, the sound pressure level can be as low as 23dBA.

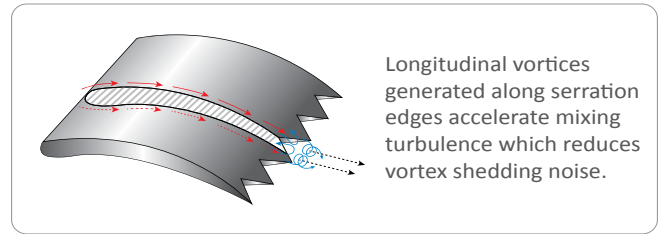

Branch Duct Connection

Improves air flow distribution when there is an obstruction. It allows for air conditioning of two rooms simultaneously.

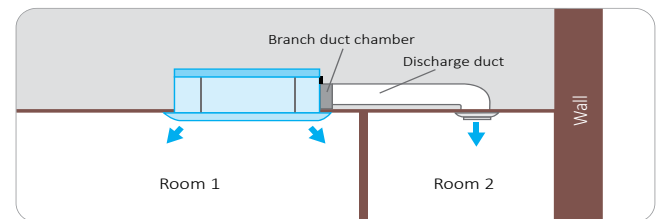

Low Height Design

Unit height as low as 265mm for installation convenience.

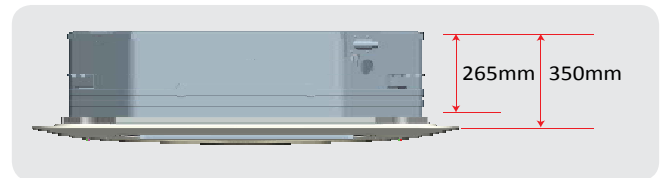

Modern & Elegant Panel

It is designed with unique "round" side contour and new LED light location. The rotatable intake grill promotes uniform installation as well.



Ceiling Cassette 3x3 (50Hz)

Built In High Head Drain Pump & Water Flow Switch

The unit comes with a 700 mm built-in high head drain pump. A safety float is incorporated in the drain pump to monitor its water level.

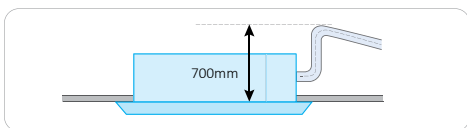

Low Water Pressure Drop

Also commonly known as low head loss actually helps to increase the system efficiency.

Self Diagnosis Features

This feature helps to detect any faults or malfunctioning in the system and provide user a warning by blinking of the LED lights.

Valve or Valveless Control Options

The design is flexible enough to allow for either valve or valveless control installation.

NIM-Able

Able to communicate with the versatile NIM networking control module and offers the opportunity of one centralized control for a system of multiple indoor units in a building.

Choices of Wired or Wireless Controller

Choices of wired BRC51A or wireless BRC52A .

Auto Restart with Last-State-Memory

In the event of a sudden power failure during operation, unit restarts automatically in 64 different recovery timing patterns (within 180 seconds to 244 seconds) and the unit will operate based on the previous setting (operating mode, temperature setting and fan speed).

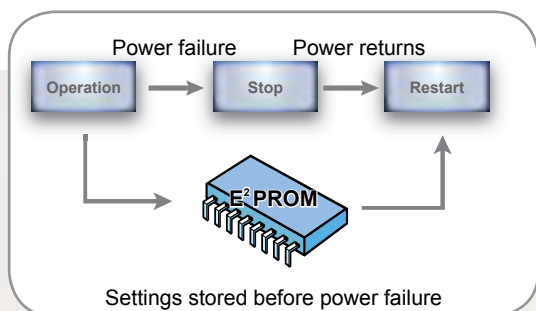

Sleep Mode

Pressing the Sleep button activates the Sleep Mode. This function prevents excessive cooling/heating for a pleasant sleep.

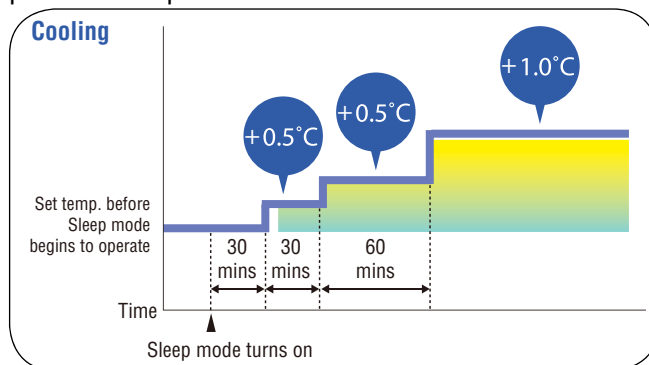

Cooling operation:

- 1) After 30 minutes, room temperature is raised by 0.5°C.
- 2) After 60 minutes, room temperature is raised by 0.5°C.
- 3) After 120 minutes, room temperature is raised by 1°C.

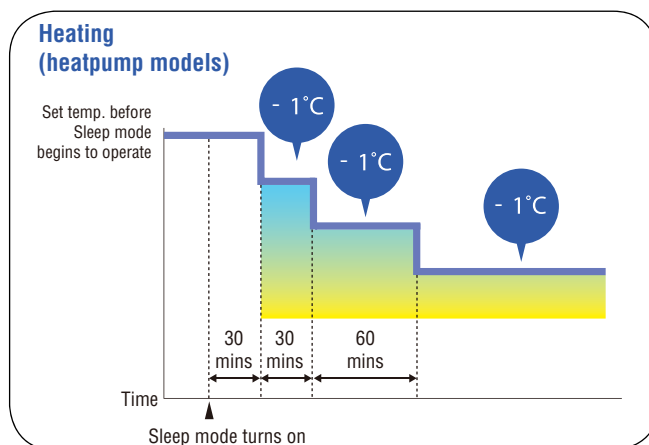

Heating operation:

- 1) After 30 minutes, room temperature is reduced by 1°C.
- 2) After 60 minutes, room temperature is reduced by 1°C.
- 3) After 120 minutes, room temperature is reduced by 1°C.

4-Pipe System Availability*

The 4-pipe system features a distribution system that contains both hot water supply (with return lines) and chilled water supply (with return lines).

* FWK-EH model

Ceiling Cassette 3x3 (50Hz)

Specification for ceiling cassette (2-pipe system)

| Indoor model name | | | FWK06E | FWK08E | FWK09E | FWK11E | FWK13E |
|--|-------------------------------|-----------------------------|--|-----------------------|-----------------------|-------------------------------------|-------------------------|
| Nominal cooling capacity | Btu/hr | | 21000 | 25000 | 30000 | 38000 | 43000 |
| | W | | 6150 | 7330 | 8790 | 11140 | 12600 |
| Nominal sensible cooling capacity | Btu/hr | | 16700 | 19200 | 22300 | 27400 | 31000 |
| | W | | 4890 | 5630 | 6540 | 8030 | 9090 |
| Nominal heating capacity (entering water temperature: 50°C) | Btu/hr | | 28000 | 33600 | 38300 | 45500 | 52000 |
| | W | | 8210 | 9850 | 11230 | 13340 | 15240 |
| Nominal total input power | W | | 95 | 126 | 167 | 186 | 227 |
| Nominal running current | A | | 0.44 | 0.55 | 0.74 | 0.85 | 1.03 |
| Power source | V/Ph/Hz | | 220-240 / 1 / 50 | | | | |
| Control | Air discharge | | 4-way automatic louver (up & down) | | | | |
| | Operation | | LCD wireless micro-computer remote control | | | | |
| Airflow (H/M/L/Q) | cfm | | 750 / 620 / 480 / 320 | 860 / 700 / 540 / 380 | 890 / 720 / 570 / 420 | 1000 / 840 / 680 / 540 | 1140 / 1000 / 840 / 700 |
| Nominal water flow rate | USGPM | | 4.71 | 5.59 | 6.69 | 8.45 | 9.60 |
| | liters/min | | 17.83 | 21.17 | 25.29 | 31.94 | 36.29 |
| Head loss (Cooling) | kPa | | 20 | 37 | 22 | 44 | 53 |
| Head loss (Heating): 50°C | kPa | | 19 | 33 | 19 | 38 | 47 |
| Max. working pressure | kPa | | 1608 | | | | |
| Surface air velocity | m/s | | 0.92 | 1.05 | 1.13 | 1.02 | 1.17 |
| Sound pressure level (H/M/L/Q) | dBA | | 42 / 38 / 32 / 23 | 46 / 42 / 35 / 27 | 48 / 43 / 38 / 30 | 50 / 47 / 43 / 33 | 52 / 49 / 45 / 39 |
| Unit dimension (Unit dimension with panel) (HxWxD) | mm | | 265 X 820 X 820 (340 X 990 X 990) | | | 300 X 820 X 820 (375 X 990 X 990) | |
| Packing dimension (Panel dimension) (HxWxD) | mm | | 341 X 916 X 916 (125 X 1020 X 1020) | | | 376 X 916 X 916 (125 X 1020 X 1020) | |
| Unit weight + panel weight | kg | | 26 + 4 | | 28 + 4 | 32 + 4 | |
| Condensate drain size | mm | | 19.05 | | | | |
| Pipe connection | mm | | 19.05 BSP female thread adaptor | | | | |
| Fan | Type | | Turbo fan | | | | |
| | Drive | | Direct | | | | |
| | Fan speed (H/M/L) | rpm | 530 / 450 / 360 | 600 / 500 / 400 | 660 / 550 / 450 | 710 / 610 / 510 | 800 / 710 / 610 |
| Fan motor | Type | | Permanent split capacitor (Induction) | | | | |
| | Index of Protection (IP) | | IP20 | | | | |
| | Insulation grade | | B | | | | |
| | Rated input power (H/M/L) | W | 95 / 79 / 67 | 126 / 103 / 89 | 167 / 109 / 86 | 186 / 151 / 118 | 227 / 176 / 144 |
| | Rated running current (H/M/L) | A | 0.44 / 0.40 / 0.36 | 0.55 / 0.45 / 0.39 | 0.74 / 0.49 / 0.39 | 0.85 / 0.71 / 0.57 | 1.03 / 0.82 / 0.69 |
| | Starting current | A | 0.44 | 0.71 | 0.89 | 1.02 | 1.28 |
| | Motor output | W | 30 | 45 | 65 | 80 | 110 |
| | Poles | | 8 | | | 6 | |
| Coil | Tube | Material | Copper | | | | |
| | | Diameter (mm) | 7.00 | | | | |
| | Fin | Material | Aluminium | | | | |
| | | Face area (m ²) | 0.39 | | 0.37 | 0.46 | |
| | | Row | 2 | | 3 | | |
| Water volume | liter | 1.36 | 1.34 | 1.97 | 2.35 | | |
| Air quality | Filter type | | Washable saranet filter | | | | |
| | Filter quantity | pc | 1 | | | | |
| Casing | Colour | | White | | | | |

| Mode | Cooling | Heating |
|----------------------------|-------------------|--|
| Entering air temperature | 27°C DB / 19°C WB | 20°C DB |
| Entering water temperature | 7°C | 50°C (2-pipe system) 70°C (4-pipe system) |
| Leaving water temperature | 12°C | 60°C (4-pipe system) |

All specifications are subjected to change by the manufacturer without prior notice.

Ceiling Cassette 3x3 (50Hz)

Specification for ceiling cassette (4-pipe system)

| Indoor model name | | | FWK06EH | FWK08EH | FWK09EH | FWK11EH | FWK13EH |
|--|-------------------------------|-----------------------------|--|-----------------------|-----------------------|-------------------------------------|-------------------------|
| Nominal cooling capacity | Btu/hr | | 16400 | 18500 | 24600 | 29600 | 31300 |
| | W | | 4800 | 5430 | 7210 | 8670 | 9160 |
| Nominal sensible cooling capacity | Btu/hr | | 14487 | 16108 | 19922 | 23991 | 25790 |
| | W | | 4250 | 4720 | 5840 | 7030 | 7560 |
| Nominal heating capacity (entering water temperature: 70°C) | Btu/hr | | 30300 | 33400 | 40500 | 51100 | 54900 |
| | W | | 8870 | 9800 | 11880 | 14990 | 16100 |
| Nominal total input power | W | | 95 | 126 | 167 | 186 | 227 |
| Nominal running current | A | | 0.44 | 0.55 | 0.74 | 0.85 | 1.03 |
| Power source | V/Ph/Hz | | 220-240 / 1 / 50 | | | | |
| Control | Air discharge | | 4-way automatic louver (up & down) | | | | |
| | Operation | | LCD wireless micro-computer remote control | | | | |
| Airflow (H/M/L/Q) | cfm | | 750 / 620 / 480 / 320 | 860 / 700 / 540 / 380 | 890 / 720 / 570 / 420 | 1000 / 840 / 680 / 540 | 1140 / 1000 / 840 / 700 |
| Nominal water flow rate (Cooling) | USGPM | | 3.65 | 4.14 | 5.46 | 6.56 | 6.96 |
| | liters/min | | 13.83 | 15.67 | 20.67 | 24.83 | 26.33 |
| Nominal water flow rate (Heating) | USGPM | | 3.35 | 3.70 | 4.49 | 5.68 | 6.12 |
| | liters/min | | 12.67 | 14.00 | 17.00 | 21.50 | 23.17 |
| Head loss (Cooling) | kPa | | 25 | 31 | 27 | 31 | 35 |
| Head loss (Heating): 70°C | kPa | | 30 | 37 | 38 | 45 | 51 |
| Max. working pressure | kPa | | 1608 | | | | |
| Surface air velocity | m/s | | 0.92 | 1.05 | 1.13 | 1.02 | 1.17 |
| Sound pressure level (H/M/L/Q) | dBA | | 42 / 38 / 32 / 23 | 46 / 42 / 35 / 27 | 48 / 43 / 38 / 30 | 50 / 47 / 43 / 33 | 52 / 49 / 45 / 39 |
| Unit dimension (Unit dimension with panel) (HxWxD) | mm | | 265 X 820 X 820 (340 X 990 X 990) | | | 300 X 820 X 820 (375 X 990 X 990) | |
| Packing dimension (Panel dimension) (HxWxD) | mm | | 341 X 916 X 916 (125 X 1020 X 1020) | | | 376 X 916 X 916 (125 X 1020 X 1020) | |
| Unit weight + panel weight | kg | | 26 + 4 | | 28 + 4 | 32 + 4 | |
| Condensate drain size | mm | | 19.05 | | | | |
| Pipe connection | mm | | 19.05 BSP female thread adaptor | | | | |
| Fan | Type | | Turbo fan | | | | |
| | Drive | | Direct | | | | |
| | Fan speed (H/M/L) | rpm | 530 / 450 / 360 | 600 / 500 / 400 | 660 / 550 / 450 | 710 / 610 / 510 | 800 / 710 / 610 |
| Fan motor | Type | | Permanent split capacitor (Induction) | | | | |
| | Index of Protection (IP) | | IP20 | | | | |
| | Insulation grade | | B | | | | |
| | Rated input power (H/M/L) | W | 95 / 79 / 67 | 126 / 103 / 89 | 167 / 109 / 86 | 186 / 151 / 118 | 227 / 176 / 144 |
| | Rated running current (H/M/L) | A | 0.44 / 0.40 / 0.36 | 0.55 / 0.45 / 0.39 | 0.74 / 0.49 / 0.39 | 0.85 / 0.71 / 0.57 | 1.03 / 0.82 / 0.69 |
| | Starting current | A | 0.44 | 0.71 | 0.89 | 1.02 | 1.28 |
| | Motor output | W | 30 | 45 | 65 | 80 | 110 |
| | Poles | | 8 | | | 6 | |
| Coil | Tube | Material | Copper | | | | |
| | | Diameter (mm) | 7.00 | | | | |
| | Fin | Material | Aluminium | | | | |
| | | Face area (m ²) | 0.39 | | 0.37 | 0.46 | |
| | | Row | 2 | | 3 | | |
| | Water volume | liter | 1.36 | | 1.97 | 2.35 | |
| Air quality | Filter type | | Washable saranet filter | | | | |
| | Filter quantity | pc | 1 | | | | |
| Casing | Colour | | White | | | | |

| Mode | Cooling | Heating |
|----------------------------|-------------------|--|
| Entering air temperature | 27°C DB / 19°C WB | 20°C DB |
| Entering water temperature | 7°C | 50°C (2-pipe system) 70°C (4-pipe system) |
| Leaving water temperature | 12°C | 60°C (4-pipe system) |

All specifications are subjected to change by the manufacturer without prior notice.

Ceiling Cassette 3x3 with Brushless DC Motor (50Hz)



FWKE-E



Wireless controller
BRC52A



Wired controller
BRC51A

- Comfortable, low noise and energy saving
- Multi comfort - 3 air swing pattern control
- Modulating fan speed control
- Fresh air intake
- Optimum air discharge
- Superior sound level
- Branch duct connection
- Low height design
- Built-in high head drain pump and water flow switch
- Low water pressure drop
- Sleep function in cool and heat modes
- Auto restart with last-state-memory
- Self-diagnosis features
- Choices of wired or wireless controller
- 4-pipe system availability*



Ceiling Cassette 3x3 with Brushless DC Motor (50Hz)

Energy Saving

Comparing to the traditional AC motor, DC motor offers the advantages of lower power input, higher efficiency and more energy savings.

- Brushless DC motor has less internal resistance and better heat dissipation in the stator coils. As a result, it has higher operating efficiencies since more heat can be dissipated via the stationary motor housing.
- This line up is an excellent option for green building projects contributing to higher energy efficiency.

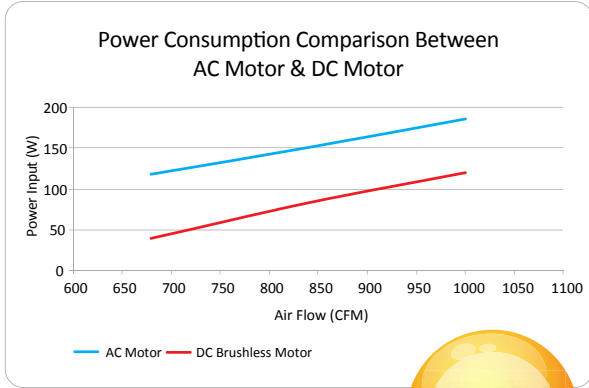

67%

Energy Saving Maximum



Low Noise

The brushless DC motor does not have a carbon brush/mechanical commutator. Therefore, it has minimum shaft friction that contributes to a lower sound level (as low as 16dBA). Other than that, the low rpm also produces low sound level.

Low Maintenance & No Brush Sparks

Without a carbon brush/mechanical commutator, the motor is low in maintenance and does not spark.

4-Pipe System Availability*

The 4-pipe system features a distribution system that contains both hot water supply (with return lines) and chilled water supply (with return lines).

* FWKE-EH model

Modulating Fan Speed Control

The fan speed modulates steplessly based on room temperature to reduce the difference between room temperature and set temperature, providing maximum comfort and reduction in energy consumption.

* Available in auto fan mode

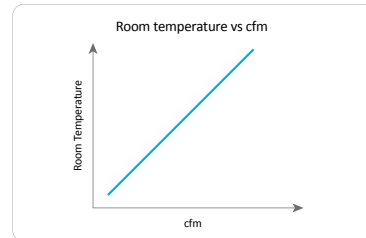

Choices of Wired or Wireless Controller

Choices of wired BRC51A or wireless BRC52A .

Recommended Applications

Ceiling cassette type fan coil with Brushless DC motor provides a green and pleasant environment.



Home



Restaurants



Offices

Ceiling Cassette 3x3 with Brushless DC Motor (50Hz)

Specification for ceiling cassette (2-pipe system)

| Indoor model name | | FWKE05E | | | | FWKE08E | | | | FWKE11E | | | | |
|--|--------------------------|--|-----------|--------|-------|---------|-------|--------|-------|-------------------------------------|-------|--------|-------|------|
| | | Quiet | Low | Medium | High | Quiet | Low | Medium | High | Quiet | Low | Medium | High | |
| Nominal cooling capacity | Btu/hr | 8200 | 11900 | 15900 | 20100 | 15200 | 19800 | 24700 | 30000 | 21000 | 26800 | 33100 | 40100 | |
| | W | 2400 | 3500 | 4650 | 5900 | 4550 | 5800 | 7250 | 8800 | 6150 | 7850 | 9700 | 11750 | |
| Nominal sensible cooling capacity | Btu/hr | 5800 | 8700 | 11700 | 15400 | 11000 | 14500 | 18500 | 21900 | 14600 | 18900 | 23800 | 28600 | |
| | W | 1710 | 2540 | 3440 | 4510 | 3220 | 4260 | 5410 | 6430 | 4270 | 5540 | 6970 | 8370 | |
| Nominal heating capacity (entering water temperature: 50°C) | Btu/hr | 11300 | 15200 | 19800 | 24200 | 18400 | 23900 | 30400 | 38200 | 24100 | 31600 | 39100 | 46700 | |
| | W | 3300 | 4450 | 5800 | 7100 | 5400 | 7000 | 8900 | 11200 | 7050 | 9250 | 11450 | 13700 | |
| Fan input power | W | 7 | 12 | 19 | 37 | 17 | 26 | 50 | 90 | 23 | 39 | 83 | 120 | |
| Nominal running current | A | 0.11 | 0.13 | 0.19 | 0.26 | 0.19 | 0.28 | 0.43 | 0.74 | 0.21 | 0.35 | 0.55 | 0.95 | |
| Power source | V/Ph/Hz | 220-240 / 1 / 50 | | | | | | | | | | | | |
| Control | Air discharge | 4-way automatic louver (up & down) | | | | | | | | | | | | |
| | Operation | LCD wireless micro-computer remote control | | | | | | | | | | | | |
| Airflow | cfm | 220 | 350 | 470 | 620 | 420 | 560 | 720 | 890 | 510 | 680 | 870 | 1060 | |
| Nominal water flow rate | USGPM | 1.84 | 2.68 | 3.56 | 4.52 | 3.41 | 4.44 | 5.55 | 6.74 | 4.71 | 6.01 | 7.43 | 9.00 | |
| | liters/min | 6.96 | 10.15 | 13.48 | 17.10 | 12.90 | 16.81 | 21.02 | 25.51 | 17.83 | 22.76 | 28.12 | 34.06 | |
| Head loss (Cooling) | kPa | 5 | 10 | 15 | 24 | 7 | 9 | 14 | 20 | 15 | 22 | 30 | 41 | |
| Head loss (Heating): 50°C | kPa | 4 | 8 | 13 | 21 | 5 | 8 | 12 | 18 | 12 | 20 | 26 | 37 | |
| Max. working pressure | kPa | 1608 | | | | | | | | | | | | |
| Surface air velocity | m/s | 0.27 | 0.43 | 0.57 | 0.76 | 0.54 | 0.71 | 0.92 | 1.13 | 0.52 | 0.70 | 0.89 | 1.08 | |
| Sound pressure level | dBA | 16 | 23 | 31 | 37 | 31 | 37 | 42 | 47 | 34 | 41 | 46 | 51 | |
| Unit dimension (Unit dimension with panel) (HxWxD) | mm | 265 X 820 X 820 (340 X 990 X 990) | | | | | | | | 300 X 820 X 820 (375 X 990 X 990) | | | | |
| Packing dimension (Panel dimension) (HxWxD) | mm | 341 X 916 X 916 (125 X 1020 X 1020) | | | | | | | | 376 X 916 X 916 (125 X 1020 X 1020) | | | | |
| Unit weight + panel weight | kg | 26 + 4 | | | | 28 + 4 | | | | 32 + 4 | | | | |
| Condensate drain size | mm | 19.05 | | | | | | | | | | | | |
| Pipe connection | mm | 19.05 BSP female thread adaptor | | | | | | | | | | | | |
| Fan | Type | Turbo fan | | | | | | | | | | | | |
| | Drive | Direct | | | | | | | | | | | | |
| | Fan speed | rpm | 200 | 280 | 360 | 450 | 350 | 440 | 550 | 660 | 400 | 510 | 630 | 750 |
| Fan motor | Type | BLDC | | | | | | | | | | | | |
| | Index of Protection (IP) | IP20 | | | | | | | | | | | | |
| | Insulation grade | E | | | | | | | | | | | | |
| | Rated running current | A | 0.11 | 0.13 | 0.19 | 0.26 | 0.19 | 0.28 | 0.43 | 0.74 | 0.21 | 0.35 | 0.55 | 0.95 |
| | Starting current | A | N/A | | | | | | | | | | | |
| | Motor output | W | 70 | | | | | | 100 | | | | | |
| | Poles | 8 | | | | | | | | | | | | |
| Coil | Tube | Material | Copper | | | | | | | | | | | |
| | | Diameter (mm) | 7.00 | | | | | | | | | | | |
| | Fin | Material | Aluminium | | | | | | | | | | | |
| | | Face area (m ²) | 0.39 | | | | 0.37 | | | | 0.46 | | | |
| | | Row | 2 | | | | 3 | | | | | | | |
| Water volume | liter | 1.36 | | | | 1.97 | | | | 2.35 | | | | |
| Air quality | Filter type | Washable saranet filter | | | | | | | | | | | | |
| | Filter quantity | pc | 1 | | | | | | | | | | | |
| Casing | Colour | White | | | | | | | | | | | | |

Note:

- A) Based on Eurovent conditions.
 B) Additional 10W is required for condensate water drain pump.
 C) Sound pressure level is tested as per JIS standard as below:
 FWKE05E - 1.4m below the face centre of air return of the unit
 FWKE08/11E - 1.5m below the face centre of air return of the unit

| Mode | Cooling | Heating |
|----------------------------|-------------------|--|
| Entering air temperature | 27°C DB / 19°C WB | 20°C DB |
| Entering water temperature | 7°C | 50°C (2-pipe system) 70°C (4-pipe system) |
| Leaving water temperature | 12°C | 60°C (4-pipe system) |

All specifications are subjected to change by the manufacturer without prior notice.

Ceiling Cassette 3x3 with Brushless DC Motor (50Hz)

Specification for ceiling cassette (4-pipe system)

| Indoor model name | | FWKE05EH | | | | FWKE08EH | | | | FWKE11EH | | | | | | |
|--|--------------------------|--|-----------|--------|-------|----------|-------|--------|-------|-------------------------------------|-------|--------|-------|------|------|--|
| | | Quiet | Low | Medium | High | Quiet | Low | Medium | High | Quiet | Low | Medium | High | | | |
| Nominal cooling capacity | Btu/hr | 6800 | 9600 | 12300 | 15000 | 13300 | 17100 | 20800 | 24600 | 17700 | 22200 | 26400 | 30700 | | | |
| | W | 2000 | 2800 | 3600 | 4400 | 3900 | 5000 | 6100 | 7200 | 5200 | 6500 | 7750 | 9000 | | | |
| Nominal sensible cooling capacity | Btu/hr | 5300 | 7600 | 10200 | 13100 | 9900 | 13000 | 16600 | 19600 | 13300 | 16700 | 20700 | 24500 | | | |
| | W | 1560 | 2240 | 2990 | 3850 | 2910 | 3810 | 4850 | 5750 | 3890 | 4900 | 6060 | 7170 | | | |
| Nominal heating capacity (entering water temperature: 70°C) | Btu/hr | 12800 | 17200 | 21700 | 26100 | 21800 | 27300 | 32800 | 38200 | 31900 | 39100 | 46200 | 53400 | | | |
| | W | 3750 | 5050 | 6350 | 7650 | 6400 | 8000 | 9600 | 11200 | 9350 | 11450 | 13550 | 15650 | | | |
| Fan input power | W | 7 | 12 | 19 | 37 | 17 | 26 | 50 | 90 | 23 | 39 | 83 | 120 | | | |
| Nominal running current | A | 0.11 | 0.13 | 0.19 | 0.26 | 0.19 | 0.28 | 0.43 | 0.74 | 0.21 | 0.35 | 0.55 | 0.95 | | | |
| Power source | V/Ph/Hz | 220-240 / 1 / 50 | | | | | | | | | | | | | | |
| Control | Air discharge | 4-way automatic louver (up & down) | | | | | | | | | | | | | | |
| | Operation | LCD wireless micro-computer remote control | | | | | | | | | | | | | | |
| Airflow | cfm | 220 | 350 | 470 | 620 | 420 | 560 | 720 | 890 | 510 | 680 | 870 | 1060 | | | |
| Nominal water flow rate (Cooling) | USGPM | 1.53 | 2.14 | 2.76 | 3.37 | 2.99 | 3.83 | 4.67 | 5.51 | 3.98 | 4.98 | 5.93 | 6.91 | | | |
| | liters/min | 5.80 | 8.12 | 10.44 | 12.75 | 11.31 | 14.49 | 17.68 | 20.87 | 15.07 | 18.84 | 22.47 | 26.09 | | | |
| Nominal water flow rate (Heating) | USGPM | 1.44 | 1.93 | 2.43 | 2.93 | 2.45 | 3.06 | 3.68 | 4.29 | 3.58 | 4.38 | 5.19 | 5.99 | | | |
| | liters/min | 5.44 | 7.31 | 9.20 | 11.09 | 9.28 | 11.58 | 13.91 | 16.23 | 13.55 | 16.60 | 19.64 | 22.68 | | | |
| Head loss (Cooling) | kPa | 5 | 9 | 13 | 18 | 6 | 10 | 15 | 19 | 12 | 19 | 24 | 32 | | | |
| Head loss (Heating): 70°C | kPa | 7 | 10 | 17 | 22 | 13 | 18 | 25 | 32 | 21 | 30 | 39 | 52 | | | |
| Max. working pressure | kPa | 1608 | | | | | | | | | | | | | | |
| Surface air velocity | m/s | 0.27 | 0.43 | 0.57 | 0.76 | 0.54 | 0.71 | 0.92 | 1.13 | 0.52 | 0.70 | 0.89 | 1.08 | | | |
| Sound pressure level | dBA | 16 | 23 | 31 | 37 | 31 | 37 | 42 | 47 | 34 | 41 | 46 | 51 | | | |
| Unit dimension (Unit dimension with panel) (HxWxD) | mm | 265 X 820 X 820 (340 X 990 X 990) | | | | | | | | 300 X 820 X 820 (375 X 990 X 990) | | | | | | |
| Packing dimension (Panel dimension) (HxWxD) | mm | 341 X 916 X 916 (125 X 1020 X 1020) | | | | | | | | 376 X 916 X 916 (125 X 1020 X 1020) | | | | | | |
| Unit weight + panel weight | kg | 26 + 4 | | | | 28 + 4 | | | | 32 + 4 | | | | | | |
| Condensate drain size | mm | 19.05 | | | | | | | | | | | | | | |
| Pipe connection | mm | 19.05 BSP female thread adaptor | | | | | | | | | | | | | | |
| Fan | Type | Turbo fan | | | | | | | | | | | | | | |
| | Drive | Direct | | | | | | | | | | | | | | |
| | Fan speed | rpm | 200 | 280 | 360 | 450 | 350 | 440 | 550 | 660 | 400 | 510 | 630 | 750 | | |
| Fan motor | Type | BLDC | | | | | | | | | | | | | | |
| | Index of Protection (IP) | IP20 | | | | | | | | | | | | | | |
| | Insulation grade | E | | | | | | | | | | | | | | |
| | Rated running current | A | 0.11 | 0.13 | 0.19 | 0.26 | 0.19 | 0.28 | 0.43 | 0.74 | 0.21 | 0.35 | 0.55 | 0.95 | | |
| | Starting current | A | N/A | | | | | | | | | | | | | |
| | Motor output | W | 70 | | | | | | 100 | | | | | | | |
| | Poles | 8 | | | | | | | | | | | | | | |
| Coil | Tube | Material | Copper | | | | | | | | | | | | | |
| | | Diameter (mm) | 7.00 | | | | | | | | | | | | | |
| | Fin | Material | Aluminium | | | | | | | | | | | | | |
| | | Face area (m ²) | 0.39 | | | | | | 0.37 | | | | | | 0.46 | |
| | | Row | 2 | | | | | | 3 | | | | | | | |
| | Water volume | liter | 1.36 | | | | | | 1.97 | | | | | | 2.35 | |
| Air quality | Filter type | Washable saranet filter | | | | | | | | | | | | | | |
| | Filter quantity | pc | 1 | | | | | | | | | | | | | |
| Casing | Colour | White | | | | | | | | | | | | | | |

Note:

- A) Based on Eurovent conditions.
- B) Additional 10W is required for condensate water drain pump.
- C) Sound pressure level is tested as per JIS standard as below:
 FWKE05EH - 1.4m below the face centre of air return of the unit
 FWKE08/11EH - 1.5m below the face centre of air return of the unit

| Mode | Cooling | Heating |
|----------------------------|-------------------|--|
| Entering air temperature | 27°C DB / 19°C WB | 20°C DB |
| Entering water temperature | 7°C | 50°C (2-pipe system) 70°C (4-pipe system) |
| Leaving water temperature | 12°C | 60°C (4-pipe system) |

All specifications are subjected to change by the manufacturer without prior notice.

Ceiling Convertible (50Hz)



FWE-E



Wireless controller
BRC52A



Wired controller
BRC51A

- Compact design
- Far air throw
- Auto air swing
- Easy serviceability and maintenance
- Versatile installation - ceiling or floor installation
- Room temperature sensing
- Sleep function in cool and heat modes
- Auto restart with last-state-memory
- Valve or valveless control options
- Self-diagnosis features
- Choices of wired or wireless controller
- NIM-abled



Ceiling Convertible (50Hz)

Compact Design

Unit height as low as 212mm for installation at low ceiling space.

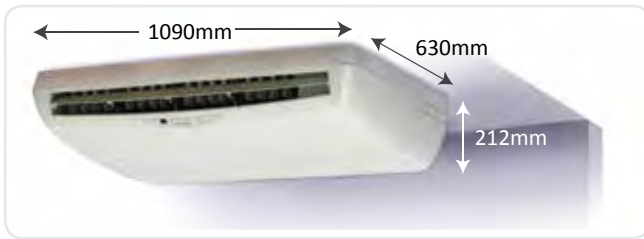

Far Air Throw

Maximum air throw distance up to 16.5m.



Auto Air Swing

The motorized louver enables the air flow to be evenly distributed.



Service & Maintenance at Ease

The washable filter can be easily accessed by just pulling down the intake grill. During servicing or repairing, only the bottom panel needs to be removed in order to access the parts like fan motor, blower, wiring connection, control box, piping connection and so on.



Ceiling and Floor Installation Option

The unit is uniquely designed with the possibility to be installed beneath the ceiling or sitting on the floor to suit any interior design requirements.

*Wall bracket is supplied as optional item.



Versatile Installation

The unit is designed to work with high pressure head drain pump (optional), offering greater flexibility for installation of condensate drain pipe. The optional drain pump comes with a high head and is incorporated with a float switch as safety protection.

* Drain pump kit supplied as optional item

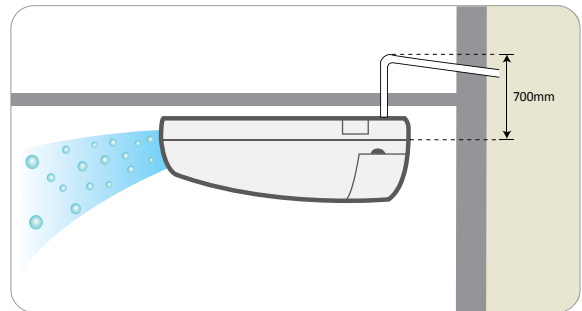

Room Temperature Sensing

Ability of unit to sense the room temperature for greater room comfort.

Saranet Air Filter

The anti-fungus air filter removes air-borne particles from the air.

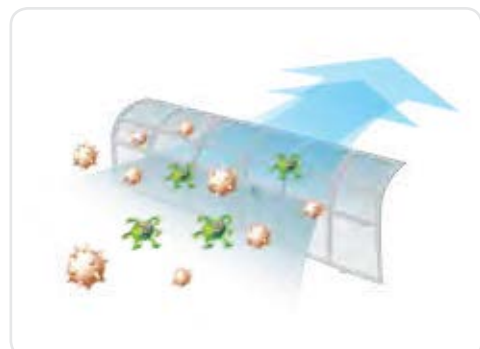

Ceiling Convertible (50Hz)

Self Diagnosis Features

This feature helps to detect any faults or malfunctioning in the system and provide user a warning by blinking of the LED lights.

Valve or Valveless Control Options

The design is flexible enough to allow for either valve or valveless control installation.

NIM-Able

Able to communicate with the versatile NIM networking control module and offers the opportunity of one centralized control for a system of multiple indoor units in a building.

Choices of Wired or Wireless Controller

Choices of wired BRC51A or wireless BRC52A .

Auto Restart with Last-State-Memory

In the event of a sudden power failure during operation, unit restarts automatically in 64 different recovery timing patterns (within 180 seconds to 244 seconds) and the unit will operate based on the previous setting (operating mode, temperature setting and fan speed).

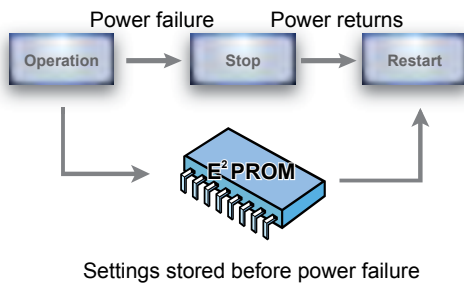

Sleep Mode

Pressing the Sleep button activates the Sleep Mode. This function prevents excessive cooling/heating for a pleasant sleep.

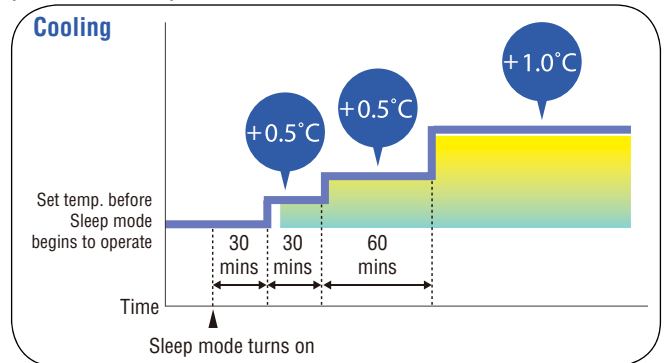

Cooling operation:

- 1) After 30 minutes, room temperature is raised by 0.5°C.
- 2) After 60 minutes, room temperature is raised by 0.5°C.
- 3) After 120 minutes, room temperature is raised by 1°C.

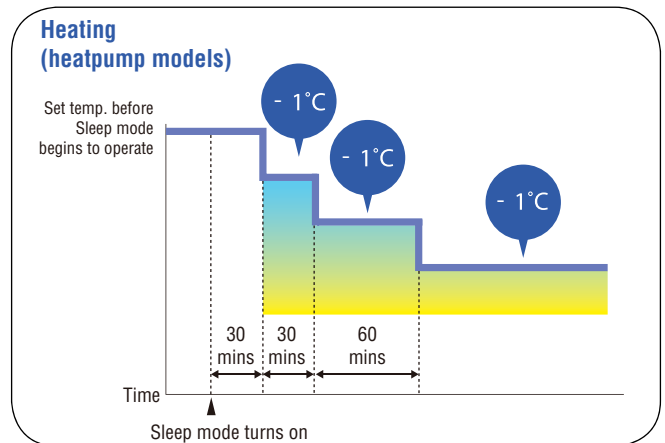

Heating operation:

- 1) After 30 minutes, room temperature is reduced by 1°C.
- 2) After 60 minutes, room temperature is reduced by 1°C.
- 3) After 120 minutes, room temperature is reduced by 1°C.



Ceiling Convertible (50Hz)

Specification for ceiling convertible

| Indoor model name | | | FWE05E | FWE06E | FWE07E | FWE08E | FWE10E | FWE12E | |
|--|-------------------------------|-----------------------------|--|--------------------|--------------------|---------------------------------|--------------------|--------------------|------|
| Nominal cooling capacity | Btu/hr | | 15500 | 20300 | 21000 | 25000 | 34000 | 47000 | |
| | W | | 4540 | 5950 | 6150 | 7330 | 9960 | 13770 | |
| Nominal sensible cooling capacity | Btu/hr | | 12700 | 15400 | 16150 | 19250 | 25500 | 32900 | |
| | W | | 3720 | 4510 | 4730 | 5640 | 7470 | 9640 | |
| Nominal heating capacity (entering water temperature: 50°C) | Btu/hr | | 19500 | 25000 | 28000 | 35000 | 47000 | 59000 | |
| | W | | 5720 | 7330 | 8210 | 10260 | 13770 | 17290 | |
| Nominal total input power | W | | 86 | 135 | 160 | 148 | 197 | 225 | |
| Nominal running current | A | | 0.38 | 0.67 | 0.79 | 0.65 | 0.87 | 0.99 | |
| Power source | V/Ph/Hz | | 220-240 / 1 / 50 | | | | | | |
| Control | Air discharge | | Automatic louver (up & down) | | | | | | |
| | Operation | | LCD wireless micro-computer remote control | | | | | | |
| Airflow (H/M/L) | cfm | | 520 / 460 / 406 | 580 / 530 / 490 | 640 / 560 / 460 | 840 / 750 / 660 | 1120 / 980 / 860 | 1230 / 1090 / 990 | |
| Nominal water flow rate | USGPM | | 3.43 | 4.49 | 4.67 | 5.77 | 7.71 | 10.17 | |
| | liters/min | | 13 | 17 | 17.68 | 21.85 | 29.19 | 38.53 | |
| Head loss (Cooling) | kPa | | 27 | 48 | 57 | 36 | 50 | 67 | |
| Head loss (Heating): 50°C | kPa | | 24 | 42 | 50 | 32 | 45 | 58 | |
| Max. working pressure | kPa | | 1608 | | | | | | |
| Surface air velocity | m/s | | 0.91 | 1.02 | 1.12 | 1.50 | 1.63 | 1.50 | |
| Sound pressure level (H/M/L) | dBA | | 45 / 38 / 36 | 48 / 43 / 39 | 49 / 46 / 41 | 48 / 47 / 44 | 52 / 47 / 46 | 52 / 50 / 49 | |
| Unit dimension (HxWxD) | mm | | 212 X 1090 X 630 | | | 259 X 1320 X 635 | 259 X 1538 X 635 | 259 X 1786 X 635 | |
| Packing dimension (HxWxD) | mm | | 297 X 1197 X 740 | | | 348 X 1393 X 734 | 348 X 1612 X 734 | 348 X 1860 X 734 | |
| Unit weight | kg | | 27 | | | 41 | 46 | 53 | |
| Condensate drain size | mm | | 19.05 | | | | | | |
| Pipe connection | mm | | 12.70 BSP female thread adaptor | | | 19.05 BSP female thread adaptor | | | |
| Fan | Type | | Blower | | | | | | |
| | Drive | | Direct | | | | | | |
| Fan speed (H/M/L) | rpm | | 1120 / 990 / 890 | 1300 / 1100 / 930 | 1400 / 1200 / 1000 | 1235 / 1120 / 1010 | 1300 / 1170 / 1090 | 1310 / 1170 / 1050 | |
| Fan motor | Type | | Permanent split capacitor (Induction) | | | | | | |
| | Index of Protection (IP) | | IP20 | | | | | | |
| | Insulation grade | | B | | | | | | |
| | Rated input power (H/M/L) | W | 86 / 58 / 51 | 135 / 97 / 83 | 160 / 113 / 91 | 148 / 138 / 126 | 197 / 169 / 153 | 225 / 190 / 173 | |
| | Rated running current (H/M/L) | A | 0.38 / 0.26 / 0.23 | 0.67 / 0.45 / 0.39 | 0.79 / 0.52 / 0.44 | 0.65 / 0.61 / 0.55 | 0.87 / 0.74 / 0.67 | 0.99 / 0.84 / 0.76 | |
| | Starting current | A | 1.10 | 1.20 | 1.30 | 1.15 | 1.54 | 1.88 | |
| | Motor output | W | 50 | 65 | 70 | 92 | 118 | 149 | |
| Poles | | | 4 | | | | | | |
| Coil | Tube | Material | Copper | | | | | | |
| | | Diameter (mm) | 7.00 | | | | | | |
| | Fin | Material | Aluminium | | | | | | |
| | | Face area (m ²) | | 0.27 | | | 0.26 | 0.32 | 0.38 |
| | | Row | | 3 | | | | | 4 |
| Water volume | liter | | 1.41 | | | 1.23 | 1.48 | 2.37 | |
| Air quality | Filter type | | Washable saranet filter | | | | | | |
| | Filter quantity | pc | | 2 | | | 3 | | 4 |
| Casing | Colour | | White | | | Light grey | | | |

| Mode | Cooling | Heating |
|----------------------------|-------------------|----------------------|
| Entering air temperature | 27°C DB / 19°C WB | 20°C DB |
| Entering water temperature | 7°C | 50°C (2-pipe system) |
| Leaving water temperature | 12°C | |

All specifications are subjected to change by the manufacturer without prior notice.

Ceiling Convertible (50Hz)



FWE-D

- 2-way air discharge
- Auto air swing
- Saranet filter
- Versatile installation - ceiling or floor installation
- Room temperature sensing
- Sleep function in cool and heat modes
- Auto restart with last-state-memory
- Valve or valveless control options
- Self-diagnosis features
- Choices of wired or wireless controller
- NIM-abled



Wireless controller
BRC52A



Wired controller
BRC51A



Ceiling Convertible (50Hz)

2-Way Air Discharge

Equipped with 2-way air discharge, both at front and bottom discharge for better air distribution.



Auto Air Swing

The swing mode enables the air flow to be evenly distributed into the room from the front discharge area.



Ceiling and Floor Installation Option

The unit is uniquely designed with the possibility to be installed beneath the ceiling or sitting on the floor to suit any interior design requirements.



Room Temperature Sensing

Ability of unit to sense the room temperature for greater room comfort.

Saranet Air Filter

The anti-fungus air filter removes air-borne particles from the air.

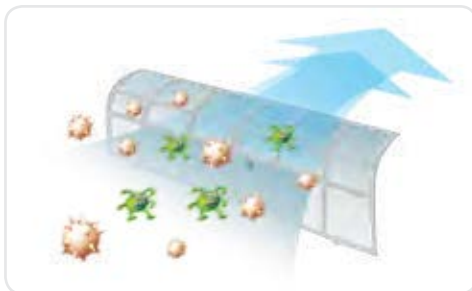

Self Diagnosis Features

This feature helps to detect any faults or malfunctioning in the system and provide user a warning by blinking of the LED lights.

Choices of Wired or Wireless Controller

Choices of wired BRC51A or wireless BRC52A .

Valve or Valveless Control Options

The design is flexible enough to allow for either valve or valveless control installation.

NIM-Able

Able to communicate with the versatile NIM networking control module and offers the opportunity of one centralized control for a system of multiple indoor units in a building.

Auto Restart with Last-State-Memory

In the event of a sudden power failure during operation, unit restarts automatically in 64 different recovery timing patterns (within 180 seconds to 244 seconds) and the unit will operate based on the previous setting (operating mode, temperature setting and fan speed).

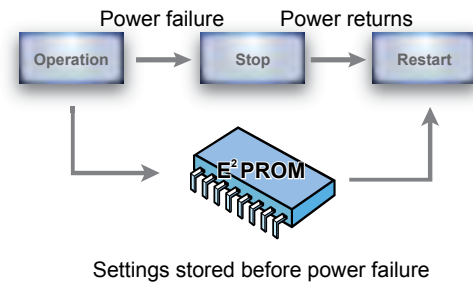

Sleep Mode

Pressing the Sleep button activates the Sleep Mode. This function prevents excessive cooling/heating for a pleasant sleep.

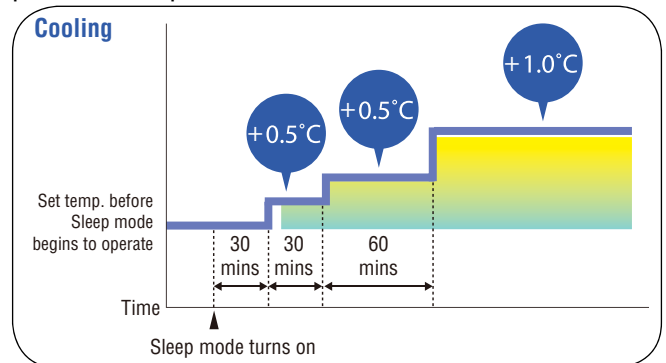

Cooling operation:

- 1) After 30 minutes, room temperature is raised by 0.5°C.
- 2) After 60 minutes, room temperature is raised by 0.5°C.
- 3) After 120 minutes, room temperature is raised by 1°C.

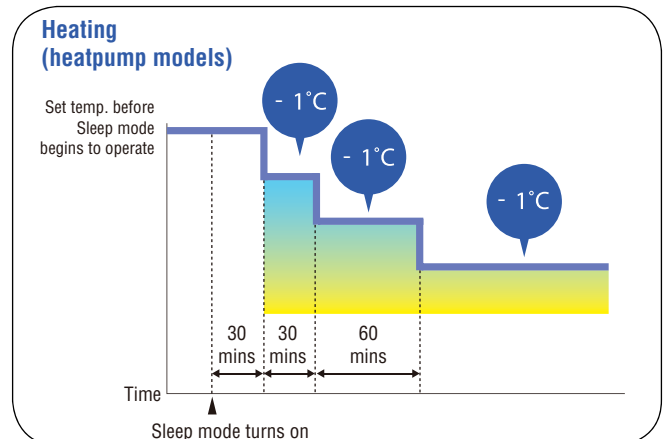

Heating operation:

- 1) After 30 minutes, room temperature is reduced by 1°C.
- 2) After 60 minutes, room temperature is reduced by 1°C.
- 3) After 120 minutes, room temperature is reduced by 1°C.

Ceiling Convertible (50Hz)

Specification for ceiling convertible

| Indoor model name | | | FWE07D | FWE09D | FWE13D |
|--|-------------------------------|-----------------------------|--|--------------------|--------------------|
| Nominal cooling capacity | Btu/hr | | 24600 | 31200 | 45000 |
| | W | | 7210 | 9140 | 13190 |
| Nominal sensible cooling capacity | Btu/hr | | 17700 | 25600 | 31400 |
| | W | | 5190 | 7500 | 9200 |
| Nominal heating capacity (entering water temperature: 50°C) | Btu/hr | | 28000 | 42300 | 51500 |
| | W | | 8210 | 12400 | 15090 |
| Nominal total input power | W | | 132 | 240 | 240 |
| Nominal running current | A | | 0.57 | 0.98 | 1.03 |
| Power source | V/Ph/Hz | | 220-240 / 1 / 50 | | |
| Control | Air discharge | | Automatic louver (up & down) | | |
| | Operation | | LCD wireless micro-computer remote control | | |
| Airflow (H/M/L) | cfm | | 697 / 688 / 650 | 956 / 908 / 889 | 1059 / 1023 / 956 |
| Nominal water flow rate | USGPM | | 5.46 | 6.91 | 9.99 |
| | liters/min | | 20.67 | 26.16 | 37.82 |
| Head loss (Cooling) | kPa | | 49 | 24 | 38 |
| Head loss (Heating): 50°C | kPa | | 43 | 22 | 32 |
| Max. working pressure | kPa | | 1608 | | |
| Surface air velocity | m/s | | 1.38 | 1.23 | 1.36 |
| Sound pressure level (H/M/L) | dB(A) | | 51 / 50 / 48 | 54 / 53 / 52 | 54 / 53 / 52 |
| Unit dimension (HxWxD) | mm | | 249 x 1214 x 670 | 249 x 1714 x 670 | |
| Packing dimension (HxWxD) | mm | | 338 x 1360 x 766 | 338 x 1860 x 766 | |
| Unit weight | kg | | 45 | 70 | |
| Condensate drain size | mm | | 19.05 | | |
| Pipe connection | mm | | 19.05 BSP female thread adaptor | | |
| Fan | Type | | Blower | | |
| | Drive | | Direct | | |
| | Fan speed (H/M/L) | rpm | 1400 / 1370 / 1260 | 1430 / 1390 / 1340 | 1430 / 1390 / 1340 |
| Fan motor | Type | | Permanent split capacitor (Induction) | | |
| | Index of Protection (IP) | | IP20 | | |
| | Insulation grade | | B | | |
| | Rated input power (H/M/L) | W | 132 / 121 / 108 | 240 / 193 / 169 | 240 / 193 / 169 |
| | Rated running current (H/M/L) | A | 0.57 / 0.51 / 0.46 | 0.98 / 0.80 / 0.70 | 1.03 / 0.83 / 0.73 |
| | Starting current | A | 0.89 | 1.02 | 1.28 |
| | Motor output | W | 65 | 100 | 120 |
| | Poles | | 4 | | |
| Coil | Tube | Material | Copper | | |
| | | Diameter (mm) | 9.53 | | |
| | Fin | Material | Aluminium | | |
| | | Face area (m ²) | 0.24 | 0.37 | |
| | | Row | 3 | 4 | |
| Water volume | liter | 2.09 | 4.25 | | |
| Air quality | Filter type | | Washable saranet filter | | |
| | Filter quantity | pc | 2 | 3 | |
| Casing | Colour | | Light grey | | |

| Mode | Cooling | Heating |
|----------------------------|-------------------|----------------------|
| Entering air temperature | 27°C DB / 19°C WB | 20°C DB |
| Entering water temperature | 7°C | 50°C (2-pipe system) |
| Leaving water temperature | 12°C | |

All specifications are subjected to change by the manufacturer without prior notice.

Ceiling Concealed (50Hz)



FWC-C

- Excellent air distribution
- Compact design
- High capacity range
- High external static pressure (ESP) range
- Double drainage protection
- Easy serviceability
- Option of left or right piping
- 4 available fan speed
- Auto restart with last-state-memory
- Valve or valveless control options
- Self-diagnosis features
- Wired controller
- NIM-abled



Wired controller
BRC51A



Ceiling Concealed (50Hz)

Excellent Air Distribution

The air can be distributed evenly to every corner of the room through ducting, enabling cooling/heating of multiple areas with one fan coil unit.



Compact Design

Unit height as low as 266mm for installation at limited ceiling space area.

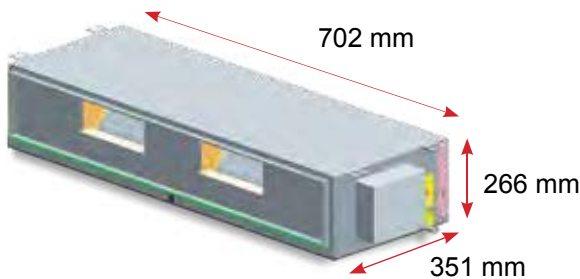

High Capacity Range

Wide capacity range from 3kW to 16kW.

Double Drain Pan Protection *

The primary drain pan is designed with high thermal insulation material and moulded in gradient for better condensate water drainage.

The extra secondary drain pan built into the standard unit offers extra protection against possible water leaking problems.

* Only applicable from FWC09C - FWC16C

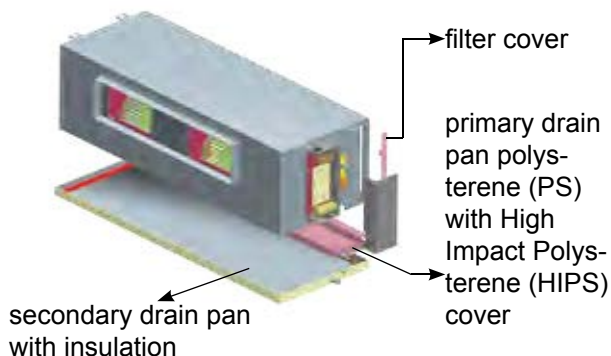

High External Static Pressure (ESP) Range

Availability of up to 167Pa ESP for high static application.

Left / Right Piping Option

For flexible installation and application at site.

Easy Serviceability

Both control box and filter is accessible from the side panel.

4 Available Fan Speed

Each speed offers different external static pressure and air flow which enhances flexibility.

Self Diagnosis Features

This feature helps to detect any faults or malfunctioning in the system and provide user a warning by blinking of the LED lights.

Valve or Valveless Control Options

The design is flexible enough to allow for either valve or valveless control installation.

NIM-Able

Able to communicate with the versatile NIM networking control module and offers the opportunity of one centralized control for a system of multiple indoor units in a building.

Auto Restart with Last-State-Memory

In the event of a sudden power failure during operation, unit restarts automatically in 64 different recovery timing patterns (within 180 seconds to 244 seconds) and the unit will operate based on the previous setting (operating mode, temperature setting and fan speed).

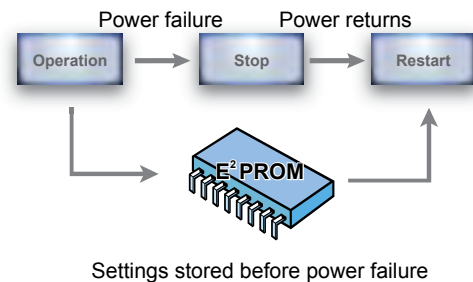

Ceiling Concealed (50Hz)

Specification for ceiling concealed

| Indoor model name | | | FWC03C | FWC04C | FWC06C | FWC07C |
|--|-------------------------------|-----------------------------|---------------------------------------|--------------------|--------------------|--------------------|
| Nominal cooling capacity | Btu/hr | | 9900 | 11600 | 18000 | 22500 |
| | W | | 2900 | 3400 | 5280 | 6590 |
| Nominal sensible cooling capacity | Btu/hr | | 7000 | 8120 | 12600 | 15750 |
| | W | | 2050 | 2380 | 3690 | 4620 |
| Nominal heating capacity (entering water temperature: 50°C) | Btu/hr | | 11500 | 15000 | 23000 | 29000 |
| | W | | 3370 | 4400 | 6740 | 8500 |
| Nominal total input power | W | | 89 | 140 | 168 | 182 |
| Nominal running current | A | | 0.40 | 0.65 | 0.77 | 0.86 |
| Power source | V/Ph/Hz | | 220-240 / 1 / 50 | | | |
| Control | Air discharge | | Ducted | | | |
| | Operation | | Wired micro-computer remote control | | | |
| Airflow (H/M/L) | cfm | | 300 / 285 / 260 | 510 / 490 / 400 | 700 / 675 / 640 | 730 / 660 / 580 |
| External Static Pressure (H/M/L) | Pa | | 49 / 44 / 36 | 49 / 42 / 28 | 49 / 45 / 41 | 49 / 43 / 30 |
| Nominal water flow rate | USGPM | | 2.20 | 2.60 | 4.05 | 5.06 |
| | liters/min | | 8.33 | 9.84 | 15.33 | 19.15 |
| Head loss (Cooling) | kPa | | 10.5 | 24 | 20.1 | 32.4 |
| Head loss (Heating): 50°C | kPa | | 8.8 | 20.3 | 17.0 | 27.6 |
| Max. working pressure | kPa | | 1608 | | | |
| Surface air velocity | m/s | | 1.23 | 1.68 | 1.88 | 1.70 |
| Sound pressure level (H/M/L) | dB(A) | | 36 / 35 / 33 | 40 / 38 / 33 | 42 / 41 / 40 | 41 / 40 / 36 |
| Unit dimension (HxWxD) | mm | | 267 x 702 x 351 | 267 x 842 x 351 | 267 x 1002 x 351 | 267 x 1137 x 351 |
| Packing dimension (HxWxD) | mm | | 376 x 951 x 541 | 376 x 1091 x 541 | 376 x 1251 x 541 | 376 x 1386 x 541 |
| Unit weight | kg | | 18 | 22 | 24 | 26 |
| Condensate drain size | mm | | 19.05 | | | |
| Pipe connection | mm | | 19.05 BSP female thread adaptor | | | |
| Fan | Type | | Blower | | | |
| | Drive | | Direct | | | |
| Fan speed (H/M/L) | rpm | | 1282 / 1221 / 1117 | 1385 / 1279 / 1078 | 1369 / 1331 / 1263 | 1348 / 1270 / 1072 |
| Fan motor | Type | | Permanent split capacitor (Induction) | | | |
| | Index of Protection (IP) | | IP20 | | | |
| | Insulation grade | | B | | | |
| | Rated input power (H/M/L) | W | 89 / 86 / 78 | 140 / 128 / 127 | 168 / 165 / 163 | 182 / 175 / 163 |
| | Rated running current (H/M/L) | A | 0.40 / 0.39 / 0.35 | 0.65 / 0.59 / 0.59 | 0.77 / 0.76 / 0.75 | 0.86 / 0.83 / 0.77 |
| | Starting current | A | 0.73 | 1.66 | 1.22 | 1.86 |
| | Motor output | W | 38 | 72 | 80 | 90 |
| Poles | | | 4 | | | |
| Coil | Tube | Material | Copper | | | |
| | | Diameter (mm) | 9.52 | | | |
| | Fin | Material | Aluminium | | | |
| | | Face area (m ²) | 0.11 | 0.14 | 0.18 | 0.20 |
| | Row | | 3 | | | |
| Water volume | liter | 0.90 | 1.20 | 1.40 | 1.60 | |
| Air quality | Filter type | | Washable saranet filter | | | |
| | Filter quantity | pc | 1 | | | |
| Casing | Colour | | Without paint | | | |

| Mode | Cooling | Heating |
|----------------------------|-------------------|----------------------|
| Entering air temperature | 27°C DB / 19°C WB | 20°C DB |
| Entering water temperature | 7°C | 50°C (2-pipe system) |
| Leaving water temperature | 12°C | |

All specifications are subjected to change by the manufacturer without prior notice.

Ceiling Concealed (50Hz)

Specification for ceiling concealed

| Indoor model name | | | FWC09C | FWC11C | FWC12C | FWC14C | FWC16C |
|--|-------------------------------|-----------------------------|---------------------------------------|--------------------|--------------------|--------------------|--------------------|
| Nominal cooling capacity | Btu/hr | | 24800 | 38000 | 37000 | 44700 | 51800 |
| | W | | 7270 | 11140 | 10840 | 13100 | 15180 |
| Nominal sensible cooling capacity | Btu/hr | | 19700 | 29800 | 29300 | 35100 | 40900 |
| | W | | 5770 | 8730 | 8590 | 10290 | 11990 |
| Nominal heating capacity (entering water temperature: 50°C) | Btu/hr | | 32800 | 49200 | 48000 | 54900 | 65300 |
| | W | | 9610 | 14420 | 14070 | 16090 | 19140 |
| Nominal total input power | W | | 345 | 504 | 442 | 427 | 531 |
| Nominal running current | A | | 1.50 | 2.28 | 1.93 | 1.86 | 2.32 |
| Power source | V/Ph/Hz | | 220-240 / 1 / 50 | | | | |
| Control | Air discharge | | Ducted | | | | |
| | Operation | | Wired micro-computer remote control | | | | |
| Airflow (H/M/L) | cfm | | 830 / 760 / 710 | 1250 / 1130 / 1040 | 1240 / 1100 / 1020 | 1340 / 1220 / 1190 | 1550 / 1400 / 1300 |
| External Static Pressure (H/M/L) | Pa | | 167 / 128 / 88 | 118 / 108 / 88 | 128 / 88 / 39 | 157 / 137 / 108 | 157 / 137 / 98 |
| Nominal water flow rate | USGPM | | 5.55 | 8.59 | 8.28 | 10.04 | 11.62 |
| | liters/min | | 21.01 | 32.51 | 31.34 | 38.00 | 43.98 |
| Head loss (Cooling) | kPa | | 14 | 39 | 23 | 38 | 51 |
| Head loss (Heating): 50°C | kPa | | 11 | 37 | 19 | 33 | 48 |
| Max. working pressure | kPa | | 1608 | | | | |
| Surface air velocity | m/s | | 1.41 | 1.75 | 1.83 | 1.54 | 1.52 |
| Sound pressure level (H/M/L) | dBA | | 46 / 42 / 38 | 51 / 48 / 45 | 49 / 45 / 41 | 52 / 50 / 47 | 53 / 50 / 47 |
| Unit dimension (HxWxD) | mm | | 384 x 917 x 462 | 316 x 1225 x 559 | 384 x 1003 x 462 | 384 x 1287 x 462 | 384 x 1487 x 462 |
| Packing dimension (HxWxD) | mm | | 415 x 1126 x 631 | 355 x 1461 x 727 | 415 x 1245 x 631 | 415 x 1497 x 631 | 415 x 1701 x 631 |
| Unit weight | kg | | 42 | 47 | 44 | 50 | 56 |
| Condensate drain size | mm | | 19.05 | | | | |
| Pipe connection | mm | | 19.05 BSP female thread adaptor | | | | |
| Fan | Type | | Blower | | | | |
| | Drive | | Direct | | | | |
| Fan speed (H/M/L) | rpm | | 1230 / 1093 / 937 | 1381 / 1268 / 1169 | 1260 / 1097 / 913 | 1284 / 1203 / 1108 | 1303 / 1215 / 1067 |
| Fan motor | Type | | Permanent split capacitor (Induction) | | | | |
| | Index of Protection (IP) | | IP20 | IP21 | IP22 | IP20 | |
| | Insulation grade | | B | | | | |
| | Rated input power (H/M/L) | W | 345 / 304 / 270 | 504 / 380 / 338 | 442 / 384 / 342 | 427 / 388 / 373 | 531 / 466 / 413 |
| | Rated running current (H/M/L) | A | 1.50 / 1.34 / 1.21 | 2.28 / 1.72 / 1.53 | 1.93 / 1.69 / 1.54 | 1.86 / 1.69 / 1.63 | 2.32 / 2.02 / 1.81 |
| | Starting current | A | 2.43 | 2.77 | 3.18 | 3.50 | 4.90 |
| | Motor output | W | 310 | 470 | 355 | 373 | 500 |
| | Poles | | 4 | | | | |
| Coil | Tube | Material | Copper | | | | |
| | | Diameter (mm) | 9.52 | | | | |
| | Fin | Material | Aluminium | | | | |
| | | Face area (m ²) | 0.28 | 0.34 | 0.32 | 0.41 | 0.48 |
| | | Row | 3 | | | | |
| Water volume | liter | 2.20 | 2.70 | 2.60 | 3.30 | 3.80 | |
| Air quality | Filter type | | Washable saranet filter | | | | |
| | Filter quantity | pc | 2 | | | | |
| Casing | Colour | | Without paint | | | | |

| Mode | Cooling | Heating |
|----------------------------|-------------------|----------------------|
| Entering air temperature | 27°C DB / 19°C WB | 20°C DB |
| Entering water temperature | 7°C | 50°C (2-pipe system) |
| Leaving water temperature | 12°C | |

All specifications are subjected to change by the manufacturer without prior notice.

Ceiling Concealed High Delta-T (50Hz)

FWC-FD



- High delta-T and district cooling application
- Excellent air distribution
- Compact design
- Medium external static pressure (ESP) range
- 3 selectable fan speed
- Easy installation and serviceability
- Option of left or right piping
- Various options to meet project requirements
- Metal construction
- FCU selection software
- Eurovent certified and listed



Ceiling Concealed High Delta-T (50Hz)

Customised for high delta-T application

FWC-FD series caters for applications requiring high water temperature difference (up to 9°C) such as district cooling. At such conditions, FWC-FD performance and capacity can be well maintained.

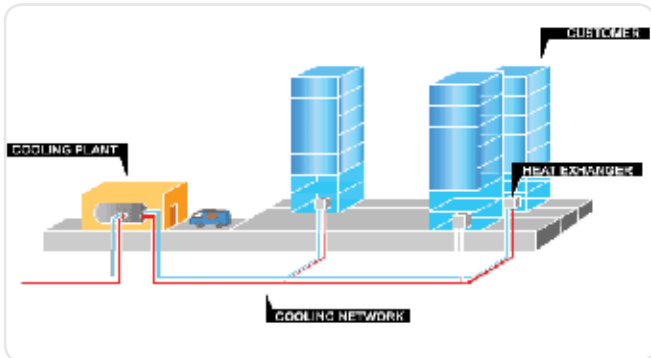

Ease of installation and serviceability

The FWC-FD series are flexible, easy to install and service.



Side removal (both left and right)



Bottom removal

Interconnected air filters: All air filters are interconnected and can easily be removed during servicing.

Bottom accessibility: Removable access panel at bottom for inspection without removing the entire unit from the ceiling.



Metal construction

Components and parts of the FWC-FD series such as casing, drain pan and blower are made of metal for its solidness and compliance to fire regulation.

FCU Selection Software

In support of FCU sales, the FCU Selection Software is available for the ease of unit selection for projects.

Eurovent certified and listed

The FWC-FD series are Eurovent certified. Its performance are tested according to the European and International standards.



Various options to meet project requirements

The FWC-FD series have several options that are readily available from the factory without modification:

- Pipe connecting direction: Right piping and left piping (facing FCU air discharge).
- Insulation type: Standard with PE insulation, option with NBR insulation (Class 0 Fire Retardant).



PE insulation



NBR insulation

- Filter type: Standard with 8mm saranet filter, option of 1 inch aluminium mesh filter.



8mm saranet filter



Aluminium mesh filter

Compact design

Considering the installation space, the FWC-FD series features low height for low ceiling space. Throughout the entire series, unit height remains at 247 mm while its unit depth maintains at 552 mm.

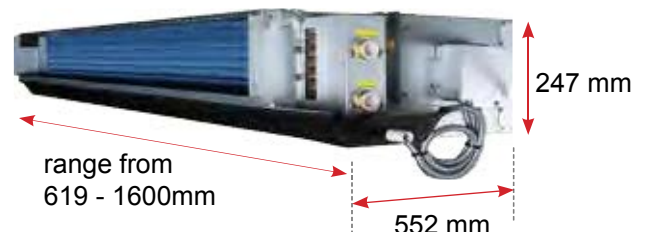

Ceiling Concealed High Delta-T (50Hz)

Specification for ceiling concealed high delta-T

| Indoor model name | | | FWC02FD | FWC03FD | FWC04FD | FWC05FD | FWC06FD | FWC08FD | FWC10FD |
|-----------------------------------|-------------------------------|-----------------------------|---------------------------------------|----------------|----------------|----------------|----------------|----------------------------------|----------------|
| Nominal cooling capacity | Btu/hr | | 6600 | 8700 | 12100 | 14000 | 17000 | 24500 | 28500 |
| | W | | 1930 | 2550 | 3550 | 4100 | 4980 | 7180 | 8350 |
| Nominal sensible cooling capacity | Btu/hr | | 5400 | 6300 | 9500 | 9600 | 11800 | 17000 | 20200 |
| | W | | 1580 | 1850 | 2780 | 2810 | 3460 | 4980 | 5920 |
| Nominal total input power | W | | 92 | 108 | 131 | 151 | 192 | 265 | 321 |
| Nominal running current | A | | 0.42 | 0.5 | 0.58 | 0.66 | 0.95 | 1.28 | 1.57 |
| Power source | V/Ph/Hz | | 220-240 / 1 / 50 | | | | | | |
| Control | Air discharge | | Ducted | | | | | | |
| | Operation | | Without controller | | | | | | |
| Airflow (H/M/L) | cfm | | 280/270/220 | 310/300/280 | 450/430/360 | 460/450/400 | 570/560/500 | 820/800/750 | 940/920/840 |
| External Static Pressure (H/M/L) | Pa | | 53/50/34 | 53/50/44 | 55/50/40 | 78/75/60 | 77/75/61 | 78/75/66 | 78/75/67 |
| Nominal water flow rate | USGPM | | 0.84 | 1.06 | 1.5 | 1.72 | 2.11 | 3.04 | 3.52 |
| | liters/min | | 3.17 | 4.00 | 5.67 | 6.50 | 8.00 | 11.50 | 13.33 |
| Head loss (Cooling) | kPa | | 24.9 | 20.8 | 17.2 | 31.2 | 18.7 | 25.0 | 19.4 |
| Max. working pressure | kPa | | 1608 | | | | | | |
| Surface air velocity | m/s | | 1.20 | 1.33 | 1.25 | 1.28 | 1.24 | 1.29 | 1.22 |
| Sound pressure level (H/M/L) | dBA | | 40/39/36 | 40/39/37 | 41/40/37 | 42/41/39 | 45/44/41 | 47/46/45 | 48/47/45 |
| Unit dimension (HxWxD) | mm | | 247x552x619 | | 247x552x870 | | 247x552x1060 | 247x552x1390 | 247x552x1600 |
| Packing dimension (HxWxD) | mm | | 320x630x737 | | 320x630x987 | | 320x630x1177 | 320x630x1507 | 320x630x1717 |
| Unit weight | kg | | 16 | 17 | 23 | 24 | 28 | 38 | 45 |
| Condensate drain size | mm | | 19.05 | | | | | | |
| Pipe connection | mm | | 19.05 BSPT female thread adaptor | | | | | | |
| Fan | Type | | Centrifugal | | | | | | |
| | Drive | | Direct | | | | | | |
| | Quantity | | 1 | | 2 | | 3 | | 4 |
| | Fan speed (H/M/L) | rpm | 1265/1232/1107 | 1379/1356/1290 | 1290/1245/1115 | 1389/1369/1290 | 1415/1395/1283 | 1430/1415/1336 1403/1388/1337 | 1422/1402/1322 |
| Fan motor | Type | | Permanent split capacitor (Induction) | | | | | | |
| | Index of Protection (IP) | | IP20 | | | | | | |
| | Insulation grade | | B | | | | | | |
| | Quantity | | 1 | | | | | 2 | |
| | Rated input power (H/M/L) | W | 92/86/68 | 108/100/84 | 131/124/105 | 151/131/102 | 192/178/149 | 265/242/201 | 321/297/253 |
| | Rated running current (H/M/L) | A | 0.42/0.38/0.30 | 0.50/0.44/0.37 | 0.58/0.54/0.46 | 0.66/0.58/0.49 | 0.95/0.79/0.65 | 1.28/1.06/0.88 | 1.57/1.31/1.11 |
| | Starting current | A | 0.68 | 1.08 | 1.08 | 1.41 | 2.65 | 2.65/1.08 | 2.65 |
| | Motor output | W | 36 | 71 | 71 | 100 | 150 | 150/71 | 150 |
| | Poles | | 4 | | | | | | |
| Coil | Tube | Material | Copper | | | | | | |
| | | Diameter (mm) | 7.0 | | | | | | |
| | Fin | Material | Aluminium | | | | | | |
| | | Face area (m ²) | 0.11 | 0.11 | 0.17 | 0.17 | 0.22 | 0.3 | 0.36 |
| | | Row | 3 | 4 | 3 | 4 | | | |
| Water volume | liter | 0.38 | 0.63 | 0.72 | 0.96 | 1.22 | 1.67 | 1.95 | |
| Air quality | Filter type | | Washable saranet filter | | | | | | |
| | Filter quantity | pc | 2 | | | | | 3 | |
| Casing | Colour | | Without paint | | | | | | |

| Mode | Cooling |
|----------------------------|-------------------|
| Entering air temperature | 24°C DB / 18°C WB |
| Entering water temperature | 5.5°C |
| Leaving water temperature | 14.5°C |

All specifications are subjected to change by the manufacturer without prior notice.

Ducted Blower (50Hz)



FUD20/25B



FUD40/50B

- Excellent air distribution
- Cabinet construction
- High cfm range
- High external static pressure (ESP) range
- Fire resistant Polyethylene insulation
- Easy serviceability
- Option of left or right piping
- 4 available fan speed*
- Changeable drive package**
- Convertible air throw direction **



Ducted Blower (50Hz)

Excellent Air Distribution

The air can be distributed evenly to every corner of the room through ducting, enabling cooling/heating of multiple areas with one fan coil unit.



4 Available Fan Speed*

Each speed offers different external static pressure and air flow which enhances flexibility.

*Only available for FUD20/25B

High Airflow Range

Airflow ranges from 2500cfm to 4600cfm.

Convertible Air Throw Direction**

Convertible discharge air direction (vertical or horizontal air throw) provides flexibility in installation at site.

**Only available for FUD30/40B

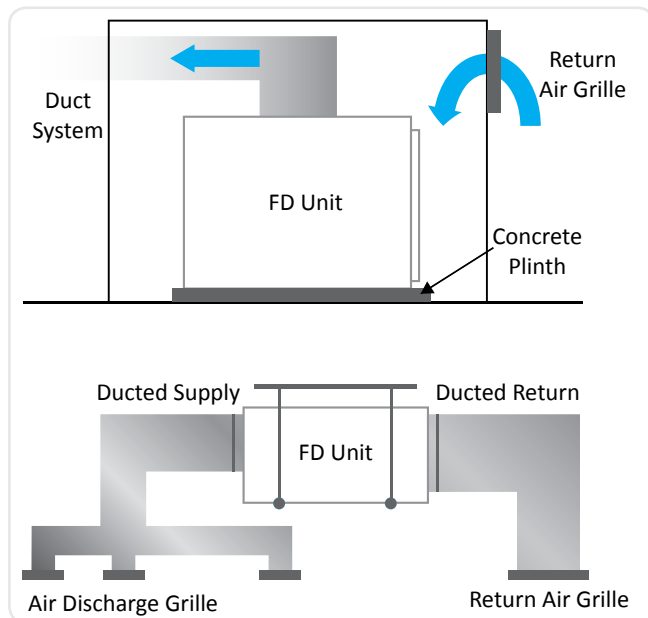

High External Static Pressure (ESP) Range

Availability of up to 230Pa ESP for high static application (without filter for FUD30/40B).

Cabinet Construction

The enclosure is made from weather-proofed electro galvanized mild steel and coated with epoxy polyester powder layer for protection against severe conditions. Service panel is also available for ease of servicing.

Left / Right Piping Option

For flexible installation and application at site.

Fire-Resistant

Polyethylene (PE) insulation is used at every possible condensate panel to prevent all forms of water or moisture penetration. Polyethylene, which is also a type of Closed Cell Foam (CCF) insulation has the following advantages:

- Durable external surface that is resilient to tough dirt.
- Higher degree of puncture resistance when compared to fiberglass.
- Easily cleaned surface (if necessary) to further resist microbial growth.

Changeable Drive Package**

Non-standard external static pressure and airflow requirements can be sized accordingly at site by changing the factory fitted drive package.

**Only available for belt driven FUD30/40B



Easy to Service

For models FUD20/25B, there is a service way allocated at the bottom for servicing.

Female Adaptor (Threaded)

The units come with threaded female adaptor, making installation at site easy by eliminating the brazing process.

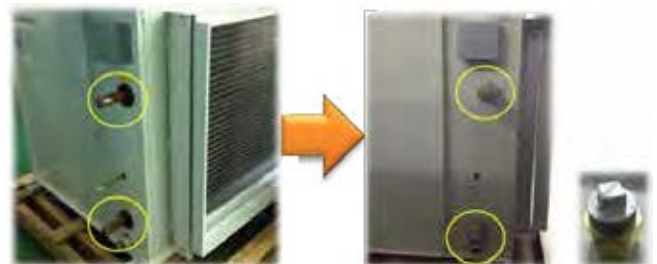

Ducted Blower (50Hz)

Specification for ducted blower

| Indoor model name | | | FUD20B | FUD25B | FUD30B | FUD40B |
|--|-------------------------------|-----------------------------|---------------------------------------|--------------------|-----------------------|------------------|
| Nominal cooling capacity | Btu/hr | | 75600 | 95000 | 125000 | 150000 |
| | W | | 22160 | 27840 | 36640 | 43960 |
| Nominal sensible cooling capacity | Btu/hr | | 53700 | 69400 | 90000 | 106500 |
| | W | | 15740 | 20340 | 26380 | 31210 |
| Nominal heating capacity (entering water temperature: 50°C) | Btu/hr | | 78000 | 97500 | 138000 | 170000 |
| | W | | 22860 | 28580 | 40450 | 49820 |
| Nominal total input power | W | | 760 | 1800 | 1620 | 1910 |
| Nominal running current | A | | 3.49 | 7.84 | 3.33 | 4.03 |
| Power source | V/Ph/Hz | | 220-240 / 1 / 50 | | 380-415 / 3 / 50 | |
| Control | Air discharge | | Ducted | | | |
| | Operation | | Without controller | | | |
| Airflow (H/M/L) | cfm | | 2500 / 2100 / 1750 | 3200 / 3000 / 2800 | 4200 / N/A / N/A | 4600 / N/A / N/A |
| External Static Pressure (H/M/L) | Pa | | 100 / 72 / 50 | 100 / 80 / 60 | 149* / N/A / N/A | 149* / N/A / N/A |
| Nominal water flow rate | USGPM | | 16.9 | 21.1 | 27.7 | 33.3 |
| | liters/min | | 64 | 80 | 105 | 126 |
| Head loss (Cooling) | kPa | | 34.5 | 42.0 | 48.8 | 53.3 |
| Head loss (Heating): 50°C | kPa | | 32.9 | 27.4 | 31.5 | 63.2 |
| Max. working pressure | kPa | | 1608 | | | |
| Surface air velocity | m/s | | 2.18 | 2.79 | 1.97 | 2.16 |
| Sound pressure level (H/M/L) | dB(A) | | 50/46/42 | 54/52/50 | 58 / N/A / N/A | |
| Unit dimension (HxWxD) | mm | | 572 x 1402 x 605 | | 885 x 1540 x 850 | |
| Packing dimension (HxWxD) | mm | | 762 x 1605 x 880 | | 1154 x 1787 x 1188 | |
| Unit weight | kg | | 92 | 102 | 176 | 189 |
| Condensate drain size | mm | | 19.05 | | | |
| Pipe connection | mm | | 31.75 BSP female thread adaptor | | | |
| Fan | Type | | Blower | | | |
| | Drive | | Direct | | Belt | |
| | Fan speed (H/M/L) | rpm | 835 / 720 / 615 | 950 / 855 / 805 | 707 / N/A / N/A | |
| Fan motor | Type | | Permanent split capacitor (Induction) | | Three phase induction | |
| | Index of Protection (IP) | | IP22 | | | |
| | Insulation grade | | B | | | |
| | Rated input power (H/M/L) | W | 760 / 611 / 478 | 1800 / 1620 / 1320 | 1620 / N/A / N/A | 1910 / N/A / N/A |
| | Rated running current (H/M/L) | A | 3.49 / 2.86 / 2.32 | 7.84 / 7.06 / 5.82 | 3.33 / N/A / N/A | 4.03 / N/A / N/A |
| | Starting current | A | 5.20 | 10.30 | 3.48 | 4.21 |
| | Motor output | W | 375 | 500 | 1500 | 1500 |
| | Poles | | 6 | | 4 | |
| Coil | Tube | Material | Copper | | | |
| | | Diameter (mm) | 9.52 | | | |
| | Fin | Material | Aluminium | | | |
| | | Face area (m ²) | 0.54 | | 1.01 | |
| | | Row | 3 | 4 | 3 | 4 |
| Water volume | liter | 4.53 | 6.27 | 8.14 | 11.63 | |
| Air quality | Filter type | | Washable saranet filter | | Viledon R29 | |
| | Filter quantity | pc | 2 | | 3 | |
| Casing | Colour | | Ivory white | | | |

* The external static pressure for FUD30/40B above is **inclusive** of R29 filters whereby R29 filters contribute a pressure drop of 81Pa.

| Mode | Cooling | Heating |
|----------------------------|-------------------|----------------------|
| Entering air temperature | 27°C DB / 19°C WB | 20°C DB |
| Entering water temperature | 7°C | 50°C (2-pipe system) |
| Leaving water temperature | 12°C | |

All specifications are subjected to change by the manufacturer without prior notice.

BRC52A

BRC52A61 – Heatpump with auto mode
 BRC52A62 – Cooling only
 BRC52A63 – Heatpump

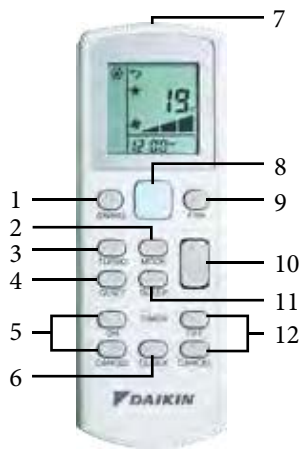

Features:

1. Vertical automatic air swing
2. Selectable mode: Auto, Cool, Heat, Dry, Fan
3. Turbo function
4. Quiet function
5. On timer setting
6. Real time clock
7. Transmission source
8. "Glow in the dark" On/Off button
9. Fan speed selection: Low, Med, High, Auto
10. Temperature setting: Up & down
11. Sleep mode function
12. Off timer setting

BRC51A

BRC51A61 – Heatpump with auto mode
 BRC51A62 – Cooling only

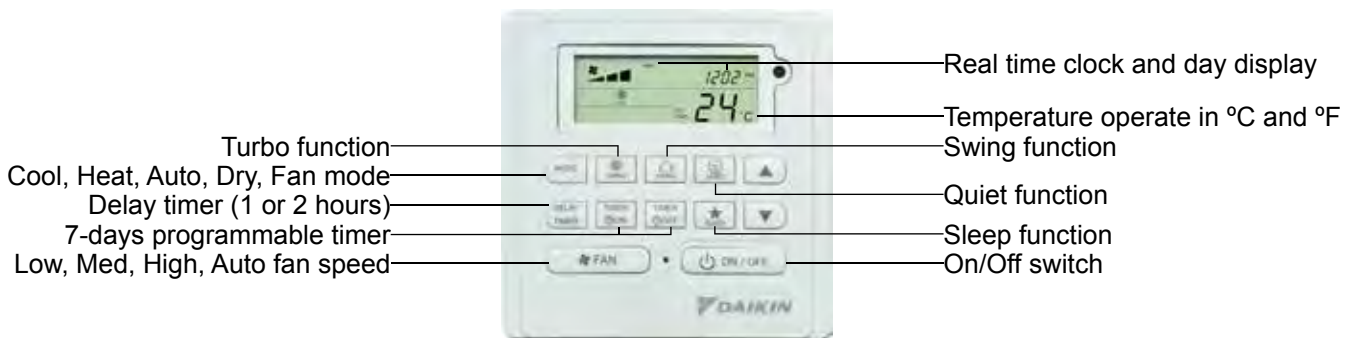

Features:

- Cool/Heat/Fan/Dry/Auto mode
- Auto/High/Med/Low fan speed
- Temperature operate in °C and °F
- Turbo and Quiet function
- Sleep function
- Swing function
- Real time clock and day display
- 7-days programmable timer
- Error indicator
- Key lock and fan lock features
- Batteries backup and retain setting during power failure
- Last state memory (memory backup setting from mainboard)
- Delay timer (1 or 2 hours)
- Interaction with wireless handset (BRC52A61/62/63)

Network Interface Module (NIM) is a networking system which enables communication among Daikin air conditioners. With the Network interface Module (NIM), all your air conditioning systems can be controlled with just a single controller providing various benefits stated below.

Network Controls NIM

Benefits:

- More convenience. No more individually controls of air conditioning units.
- Quicker and easier zone control from the master control unit.
- Better control of air conditioning systems operating conditions.

NIM utilizes master-slave type system whereby the master node will issue commands to each of the slave nodes.

Every master unit will have a group address so that every slave can only response to their respective master. Each slave unit must have a unique address so that it can be addressed independently of other nodes.

The master unit will be operating in conjunction with a control panel. Any settings done via the control panel connected to the master will overwrite the settings of its slave units.

Slave unit can be operated with or without control panel. If a slave unit is operating with a control panel, its settings can be changed without following its master.



Basic features:

- DIP switch setting for Group & Unit address.
- Master or slave system configuration.
- Automatic detection of control panel existence.
- Error type and unit ID indication through display control panel.
- Maximum point-to-point communication bus up to 1000m.
- A single master unit can control up to 15 slave units in each group.
- Each slave unit will sense their individual local temperature.
- Unit address range from 0 to 15 (0000-1111).

The NIM system consists of:

- Main board controller
- Display control panel
- NIM controller
- Communications bus

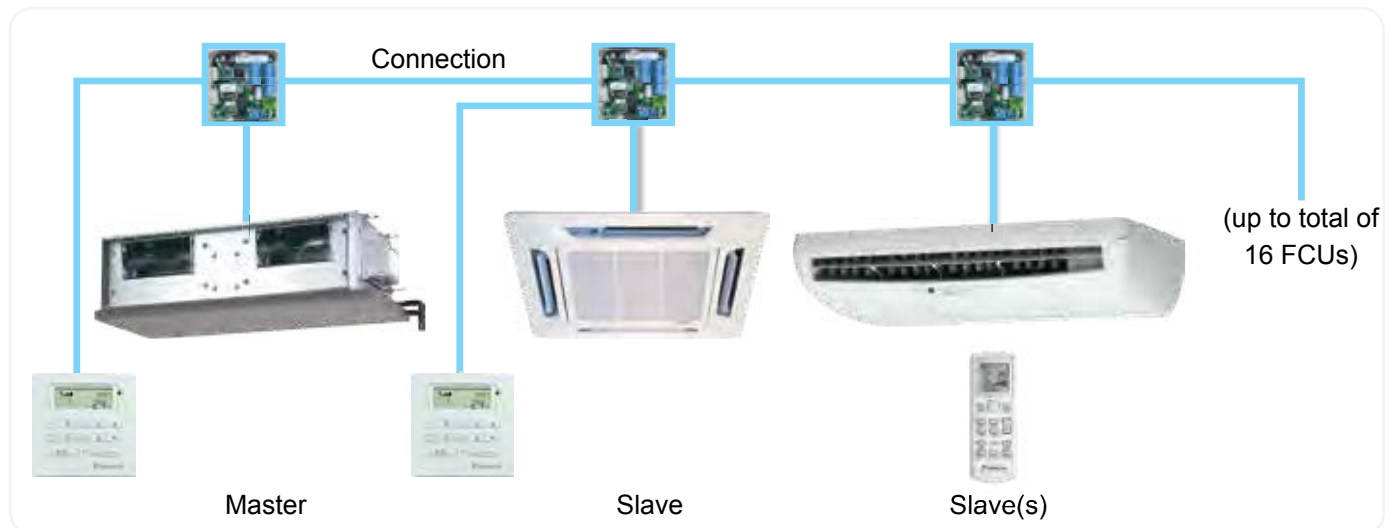

Main board controllers and display control panel

NIM must be used in conjunction with:

- Fan coil units
- BRC51A or BRC52A

Supported configuration:

| | Master | Slave |
|--------|--------|-------|
| BRC51A | • | • |
| BRC52A | - | • |

Communication Bus

A 2-way twisted pair cable is used as the communication bus. Recommended cable for communication bus is a pair of screened and shielded twisted single core wire with core diameter of 0.5mm to 1.0mm.

Connection

The communication bus must be connected serially to the adjacent NIM. (Daisy chain connection). The same polarity has to be connected between the NIMs (A to A, B to B).

| | Recommended maximum cable length (m) |
|---|--------------------------------------|
| First NIM to the furthest connected NIM | 1000 |
| NIM to main board | 10 |
| NIM to wired controller | 10 |

Warning

- Daikin products are manufactured for export to numerous countries throughout the world. Prior to purchase, please confirm with your local authorised importer, distributor and/or retailer whether this product conforms to the applicable standards, and is suitable for use, in the region where the product will be used. This statement does not purport to exclude, restrict or modify the application of any local legislation.
- Ask a qualified installer or contractor to install this product. Do not try to install the product yourself. Improper installation can result in water or refrigerant leakage, electrical shock, fire or explosion.
- Use only those parts and accessories supplied or specified by Daikin. Ask a qualified installer or contractor to install those parts and accessories. Use of unauthorised parts and accessories or improper installation of parts and accessories can result in water or refrigerant leakage, electrical shock, fire or explosion.
- Read the User's Manual carefully before using this product. The User's Manual provides important safety instructions and warnings. Be sure to follow these instructions and warnings.

If you have any enquiries, please contact your local importer, distributor and/or retailer.

Caution

Cautions on product corrosion

1. Air conditioners should not be installed in areas where corrosive gases, such as acid gas or alkaline gas, are produced.
2. If the outdoor unit is to be installed close to the sea shore, direct exposure to the sea breeze should be avoided. If you need to install the outdoor unit close to the sea shore, contact your local distributor.

Dealer**DAIKIN MALAYSIA SDN. BHD.**

Lot 60334, Persiaran Bukit Rahman Putra 3,
Taman Perindustrian Bukit Rahman Putra,
47000 Sungai Buloh, Selangor Darul Ehsan, Malaysia.
<http://www.daikinmalaysia.com>

DAIKIN INDUSTRIES, LTD.

Head office:
Umeda Center Bldg., 2-4-12, Nakazaki-Nishi,
Kita-ku, Osaka, 530-8323 Japan.